



Setup

Operation

Maintenance

In case of an error...

We will cover:

- Machine Setup
- Operational and Online diagnostics
- Maintenance
- In case of an error...



Setup

Operation

Maintenance

In case of an error...

- Check electrical cabling
- Check network topology and identify devices
- Start network

# Straight or Cross-over cable?

Setup

Operation

Maintenance

In case of an error...

- The connection between Ethernet devices must ensure that the transmitter of one device is connected to the receiver of the other device
- **Cross-over cable** are used to connect devices directly with each other

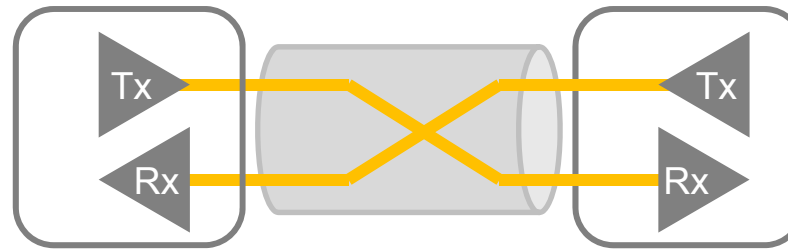

Cross-over Cable

- **Straight cable** are used as patch cables, e.g. to connect to a switch device, crossing is done in one device

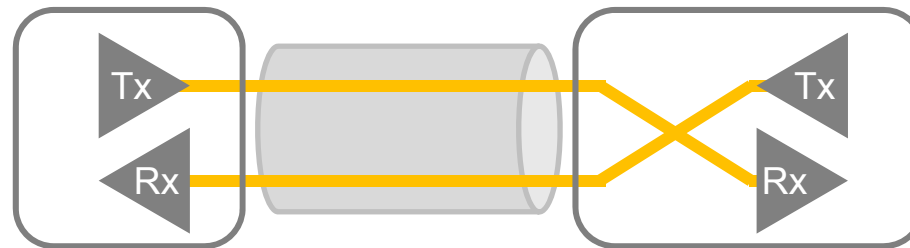

Straight Cable

Setup

Operation

Maintenance

In case of an error...

- EtherCAT slaves support **Auto-crossover** functionality
  - Each port detects automatically whether the crossing is done on cable or not
  - Cross-over and Straight cable can be used arbitrarily

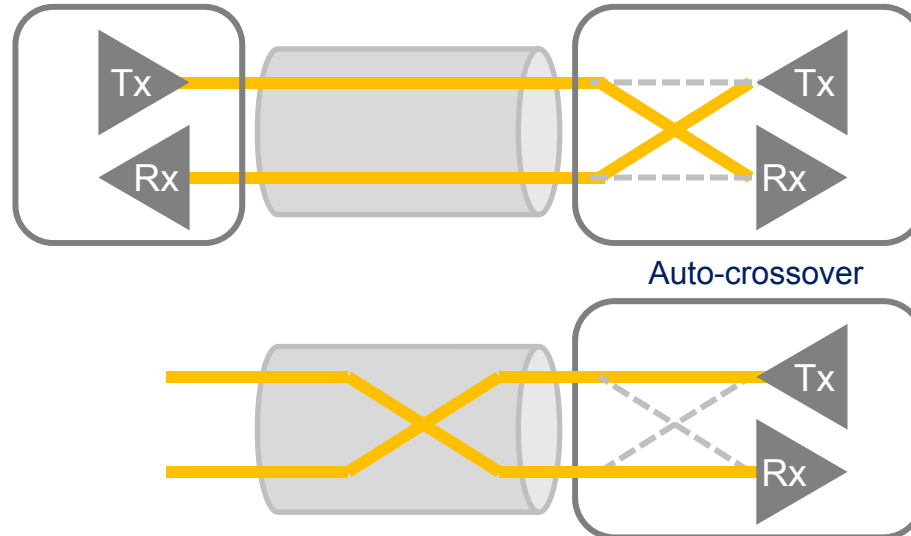

- And: Ethernet uses Peer-to-Peer connections.
  - Electrical signals are refreshed by each port
  - Full 100 m cable available between two devices

# Is a link established?

Setup

Operation

Maintenance

In case of an error...

- The simplest way of diagnosing an Ethernet connection is to observe the link indicator at both end points
- Each EtherCAT slave with removable connectors, like RJ45, M12 have a **Link/Activity Indicator** per port
  - Activity on the port means that data transfer is available  
For EtherCAT: The Master sends Frames

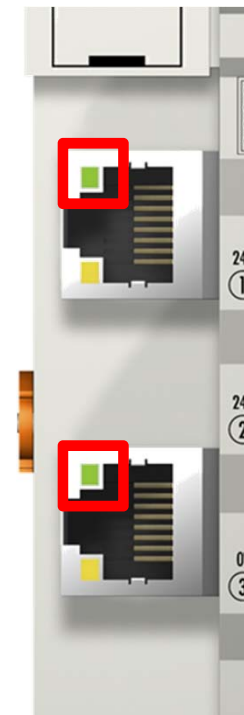

Link	Activity	Condition	Indicator
Yes	No	Port open	On
Yes	Yes	Port open	Flickering
No	N/A	Port closed	Off

- Additional, the Master can provide these information by reading according registers in the slaves

DLL Status	
Port A:	Carrier / Open
Port B:	Carrier / Open
Port C:	Carrier / Open
Port D:	No Carrier / Closed

Setup

Operation

Maintenance

In case of an error...

- According to the installation profile, EtherCAT uses shielded cable for high basic standard of noise immunity
  - The overall shield around the core pairs provides for protection against external electromagnetic interference fields for the enclosed communication cores

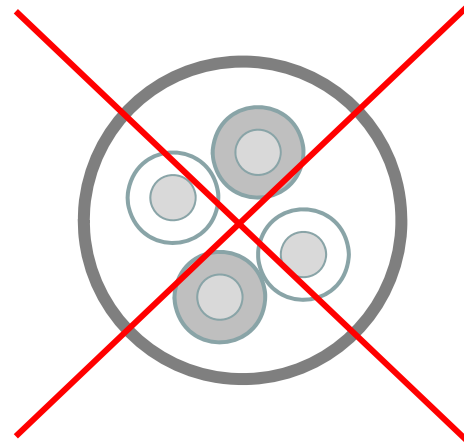

UTP  
Unshielded twisted pair

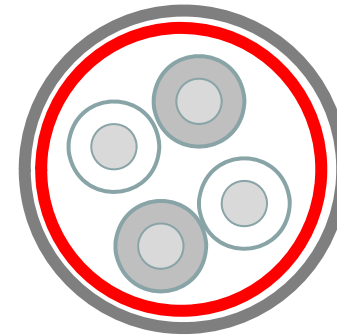

STP  
Shielded twisted pair

Setup

Operation

Maintenance

In case of an error...

- It is important for effectiveness that the shield coverage has a low impedance throughout and that it is also implemented without interruption or holes at transition points
- The shield should be connected at each end of the cable to the machine earth via an electrically conducting connection with a large surface area and low impedance.
  - A pigtail, i.e. the twisting together and point contact of the shield, should be avoided.

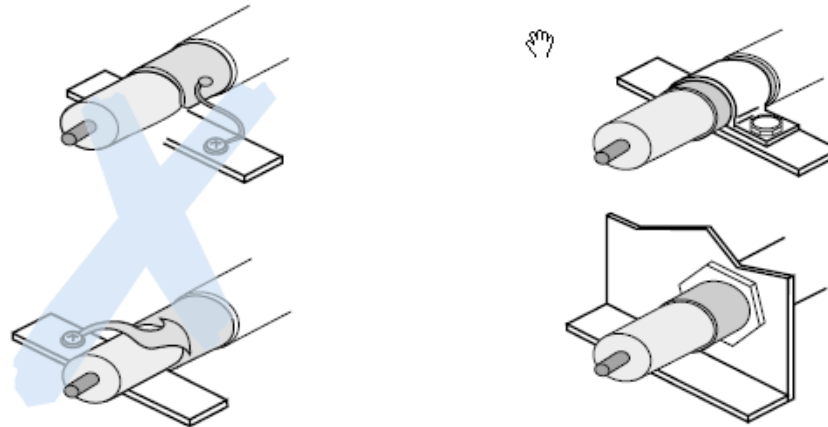

ZVEI, EMV leicht gemacht,  
Pocket Guide

Setup

Operation

Maintenance

In case of an error...

- The plug connection substantially affects the electrical characteristics of the transmission link, in particular the parameters screening effect, attenuation, crosstalk and return loss
- Shielding and internal signal routing are crucial



RJ45 connector, 4-pin,  
IP 20,  
for field-assembly



M12 connector, 4-pin,  
d-coded, IP67,  
for field-assembly



M12 socket on RJ45  
socket, straight outlet

# Example: poor execution of the cable/connector connection

- The core pairs are untwisted over an unnecessarily long distance contrary to the manufacturer's instructions

Setup

Operation

Maintenance

In case of an error...

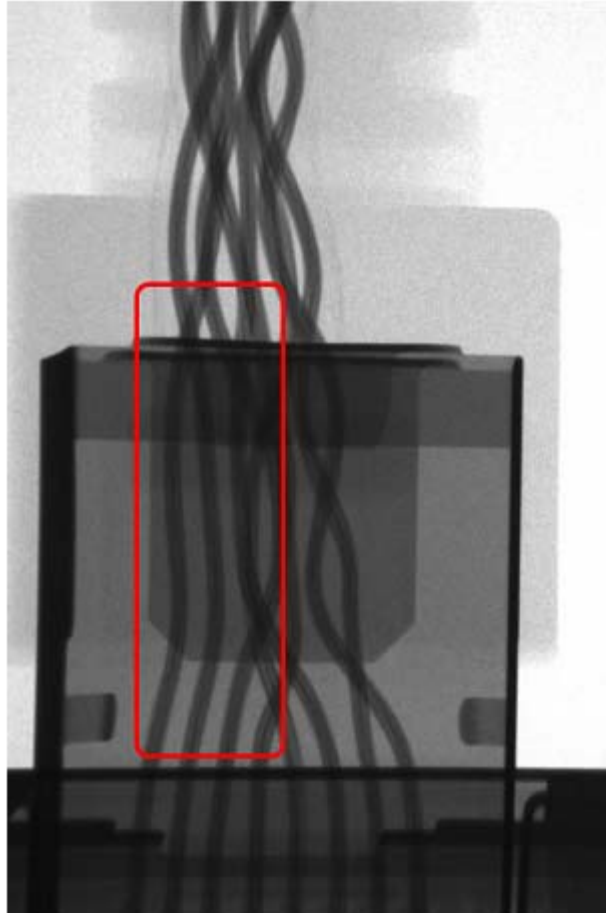

X-ray picture of an RJ45 connector

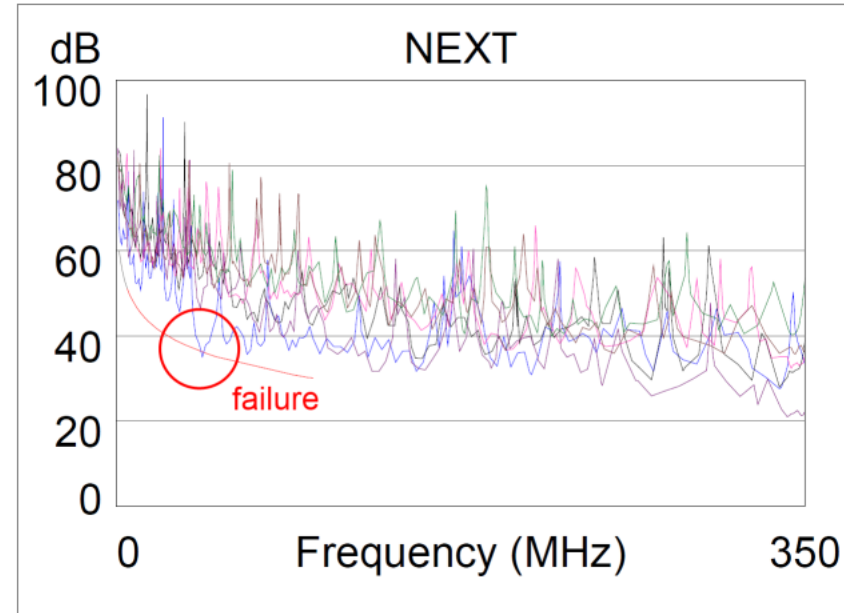

Result of the NEXT test  
(Near End Cross Talk)

Setup

Operation

Maintenance

In case of an error...

- Incomplete cable screen
  - The cable is only shielded in sections ex-works or is manufactured with insufficient coverage according to EN50288/EN50290.
- Field-configurable plug does not fit the cable used
  - If the core diameter is too small, the insulation displacement contact may not penetrate to the metal conductor and may only cut a little into the insulation.
- Compatibility
  - RJ45 plugs and sockets are not functionally compatible despite normative requirements and are prone to intermittent contacts.
- Wall feed-throughs without earth contact
  - if a metallic double coupler is used as a wall feed-through into a painted housing, the screen contact for system earthing is missing.
- Wrong assembly tool
  - Crimping tool and RJ45 plugs should be approved together by the manufacturer.
- Cable damage
  - An unsuitable cable can be damaged by repetitive movement; this may not be outwardly visible.

# Checking EtherCAT Topology

- The EtherCAT network topology can be scanned by Master using Link information of the slaves' ports

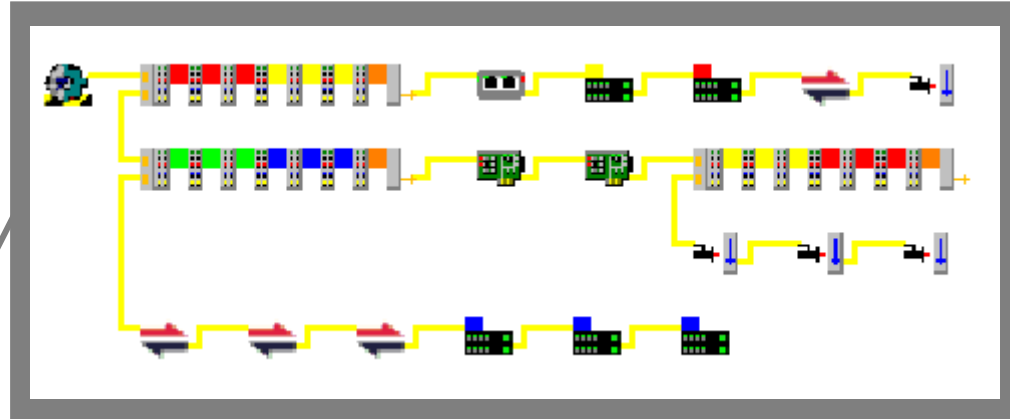

Scanned online topology

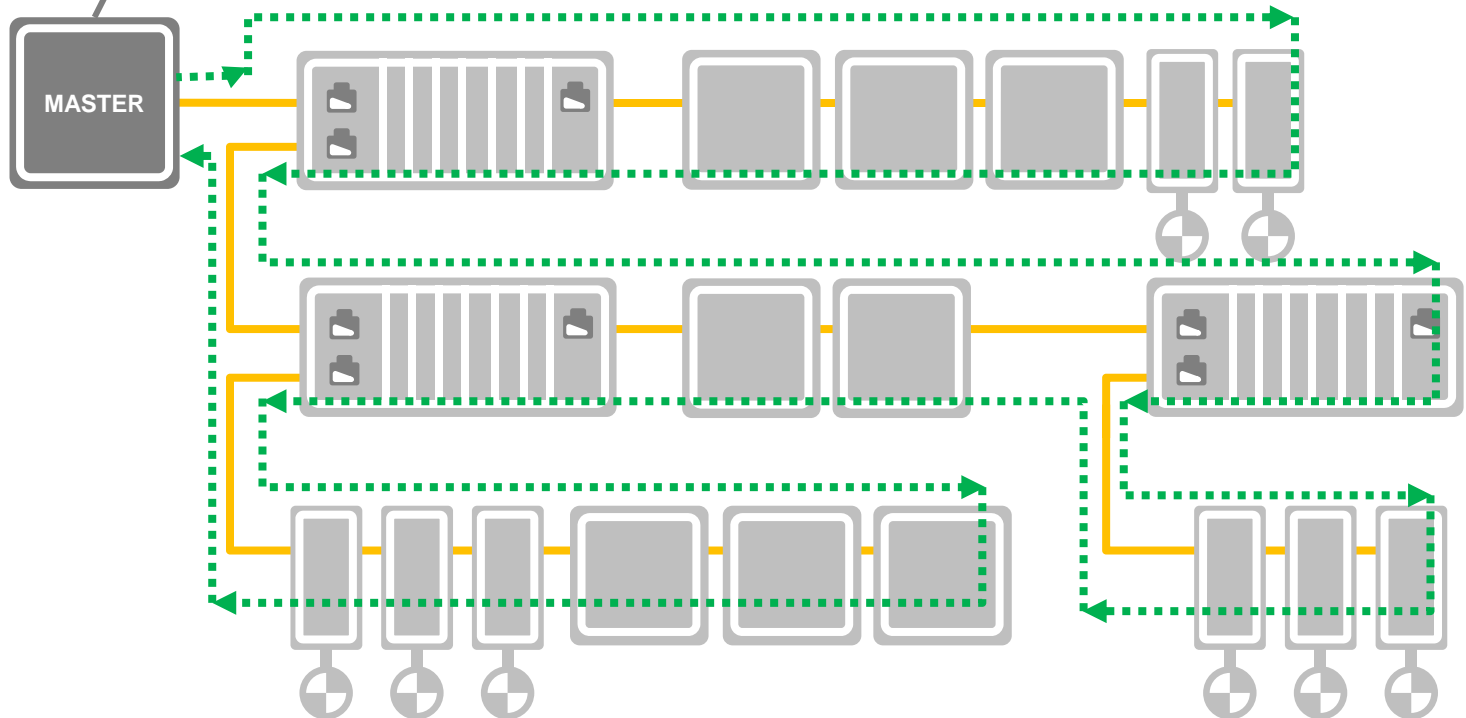

- Optional Machine parts can be connected and dis-connected while the network is running

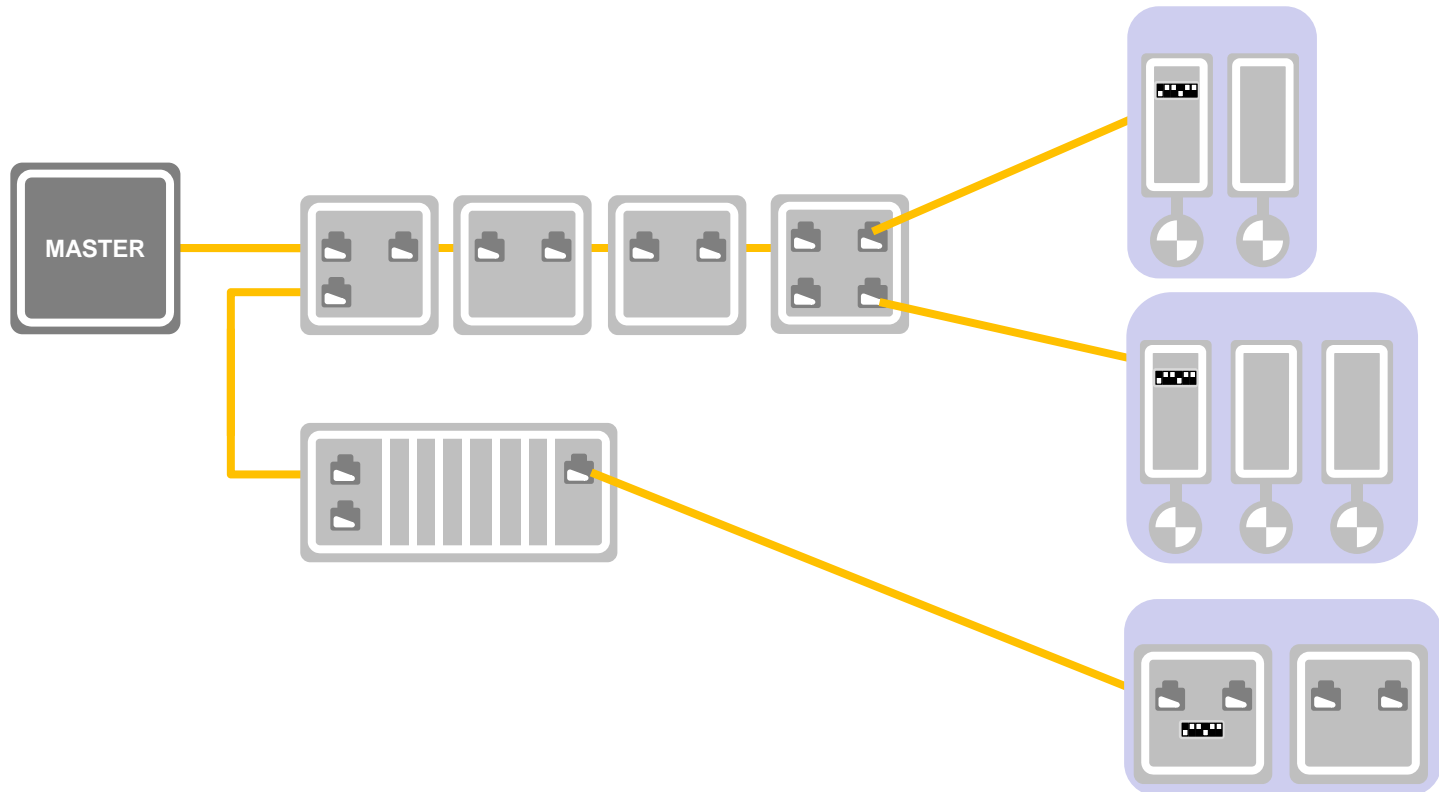

# Example: Identification of Hot-connect groups

- Hot-connects groups need a non-volatile Identification, we call it **Explicit Device ID**
  - e.g. via a DIP-Switch or E2PROM
  - Only the first device in the group needs the Explicit Device ID

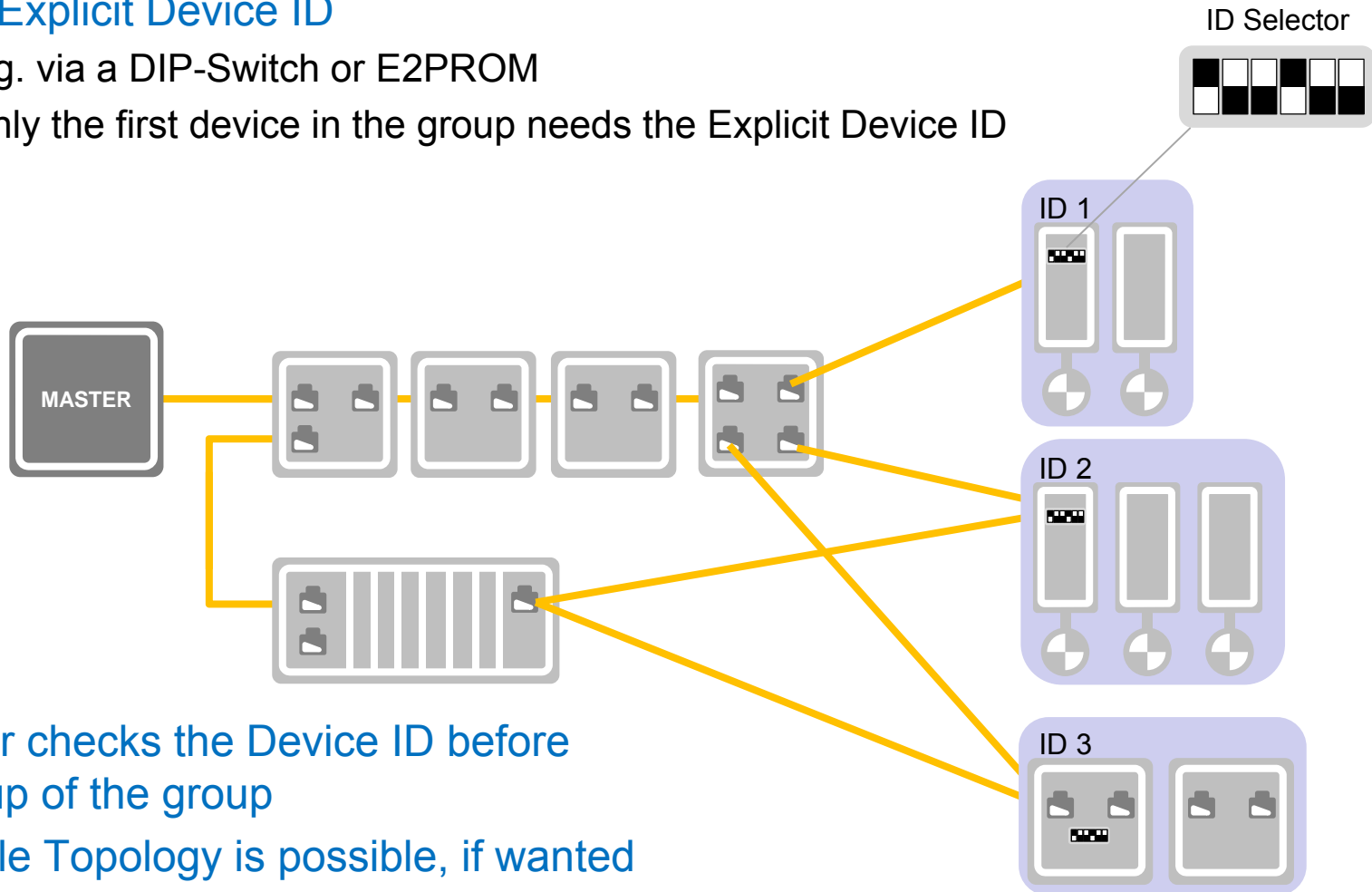

- Master checks the Device ID before boot-up of the group
- Flexible Topology is possible, if wanted

# Monitoring during network running

Online diagnosis, validity of data,  
noise issues, user information

Setup

Operation

Maintenance

In case of an error...

- All necessary slaves available and running
- Process cyclic data ... .. if valid
- Acyclic access to slaves' parameter
- Fast reaction in case of error

Setup

Operation

Maintenance

In case of an error...

Two main types of diagnostic information can be distinguished

- **Cyclic validity** of process data within each cycle
  - Consistent processing by all addressed slaves
  - Cyclic updating of process data by slaves application
  - Synchronization status
  - Current state of Slave devices
  - Transmission errors
- **Acyclic information** for additional fault diagnostic
  - Network Topology
  - Physical link status and number of link lost events
  - Hardware interface errors
  - Error counter
  - Slave identification
  - Application specific errors

Fast Reaction

Precise analysis

- Setup
- Operation
- Maintenance
- In case of an error...

- Within an EtherCAT Network several diagnosis information are provided

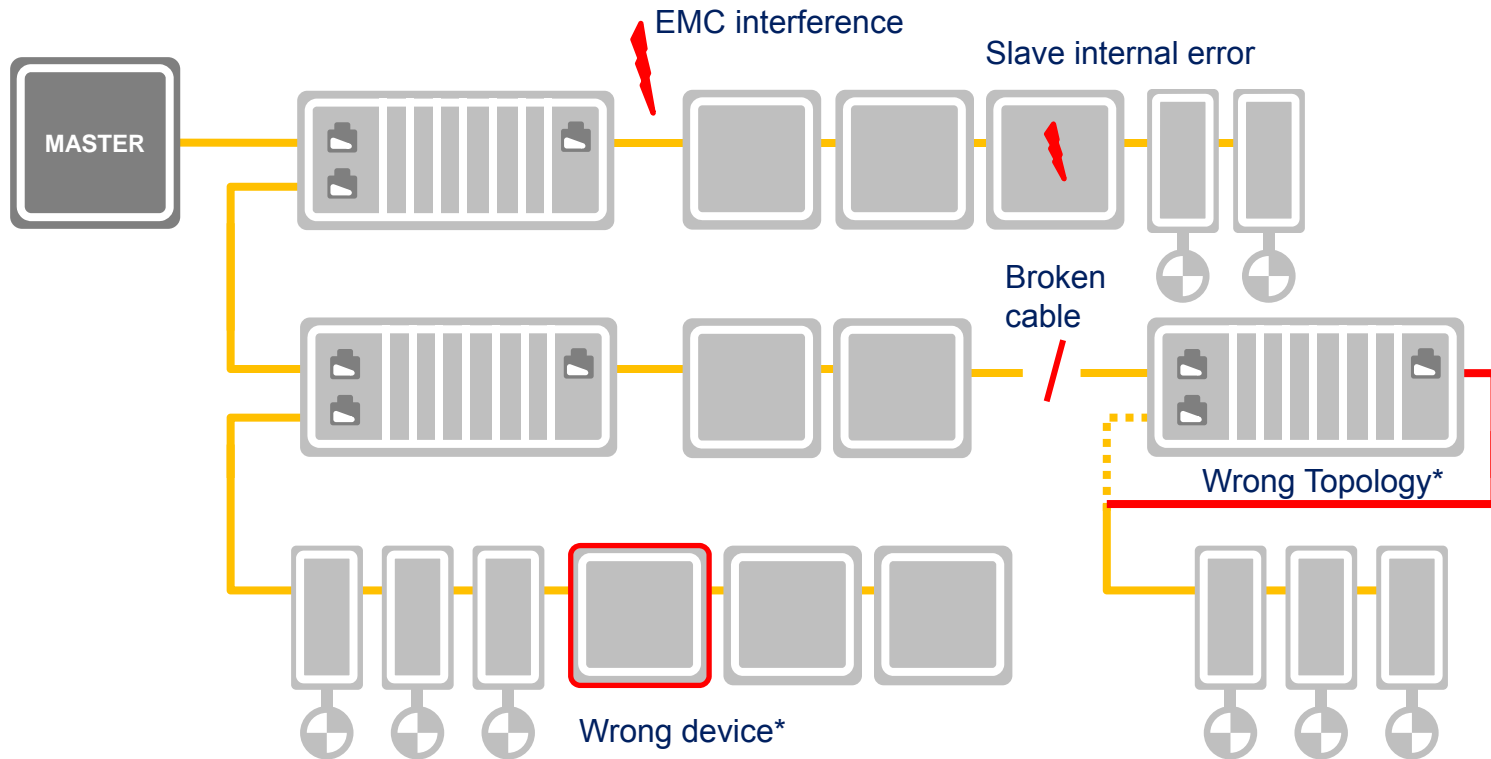

\*checked during boot-up of the network

- For a fast overview of the network behavior Master can provide Online View of all slaves

Example:  
Overview of EtherCAT Slaves  
incl. current State and  
CRC-Error information

No	Addr	Name	State	CRC
1	1001	IO_Station_A (EK1100)	OP	0, 0, 0
2	1002	StationA_DI1 (EL1002)	OP	0, 0
3	1003	StationA_DO1 (EL2202-0100)	OP	0, 0
4	1004	Safety-PLC (EL6930)	OP	0, 0
5	1005	StationA_DI2 (EL1008)	OP	0, 0
6	1006	StationA_SafeOut1 (EL2904)	OP	0, 0
7	1007	Term 7 (EK1110)	OP	0, 0
8	1008	IO_Station_B (EK1101)	OP	0, 0
9	1009	Encoder_Feedback (EL5001)	OP	0, 0
10	1010	StationB_DI1 (EL1004)	OP	0, 0
11	1011	StationB_DO1 (EL2004)	OP	0, 0
12	1012	Term 12 (EK1110)	OP	0, 0
13	1013	IO_Station_C (EK1814)	OP	0, 0
14	1014	Term 14 (EK1110)	OP	0
15	1015	IO_Station_D (EK1101)	OP	0, 0
16	1016	StationD_DI1 (EL1002)	OP	0, 0
17	1017	StationD_DO1 (EL2022)	OP	0, 0
18	1018	Term 18 (EK1110)	OP	0, 0
19	1019	IO_Station_E (EK1100)	OP	0, 0, 0
20	1020	StationE_DI1 (EL1008)	OP	0, 0
21	1021	StationE_SafeInput1 (EL1904)	OP	0, 0
22	1022	StationE_DO1 (EL2008)	OP	0, 0
23	1023	Term 23 (EK1110)	OP	0
24	1024	IO_Station_F(EK1101)	OP	0, 0
25	1025	StationF_DI1 (EL1202)	OP	0, 0
26	1026	StationF_DO1 (EL2202)	OP	0, 0
27	1027	StationF_AI1 (EL3742)	OP	0, 0
28	1028	StationF_AO1 (EL4712)	OP	0, 0
29	1029	Profibus_Gateway (EL6731)	OP	0

  

Actual State: <input type="text" value="OP"/>		Counter	Cyclic	Queued
<input type="button" value="Init"/>	<input type="button" value="Pre-Op"/>	Send Frames	2264595	+ 792381
<input type="button" value="Clear CRC"/>	<input type="button" value="Clear Frames"/>	Frames / sec	250	+ 3
<input type="button" value="Save Online Data"/>	<input type="button" value="Load Online Data..."/>	Lost Frames	2438	+ 607
<input type="button" value="Delete Online Data"/>	<input type="checkbox"/> Offline	Tx/Rx Errors	0	/ 3398

- Misbehavior in the network can easily be identified and located

CRC error on Port A

Term 18 in Operational, but **Missing Link on Port B**  
 → IO\_Station\_E and rest of network not available (No\_Comm)

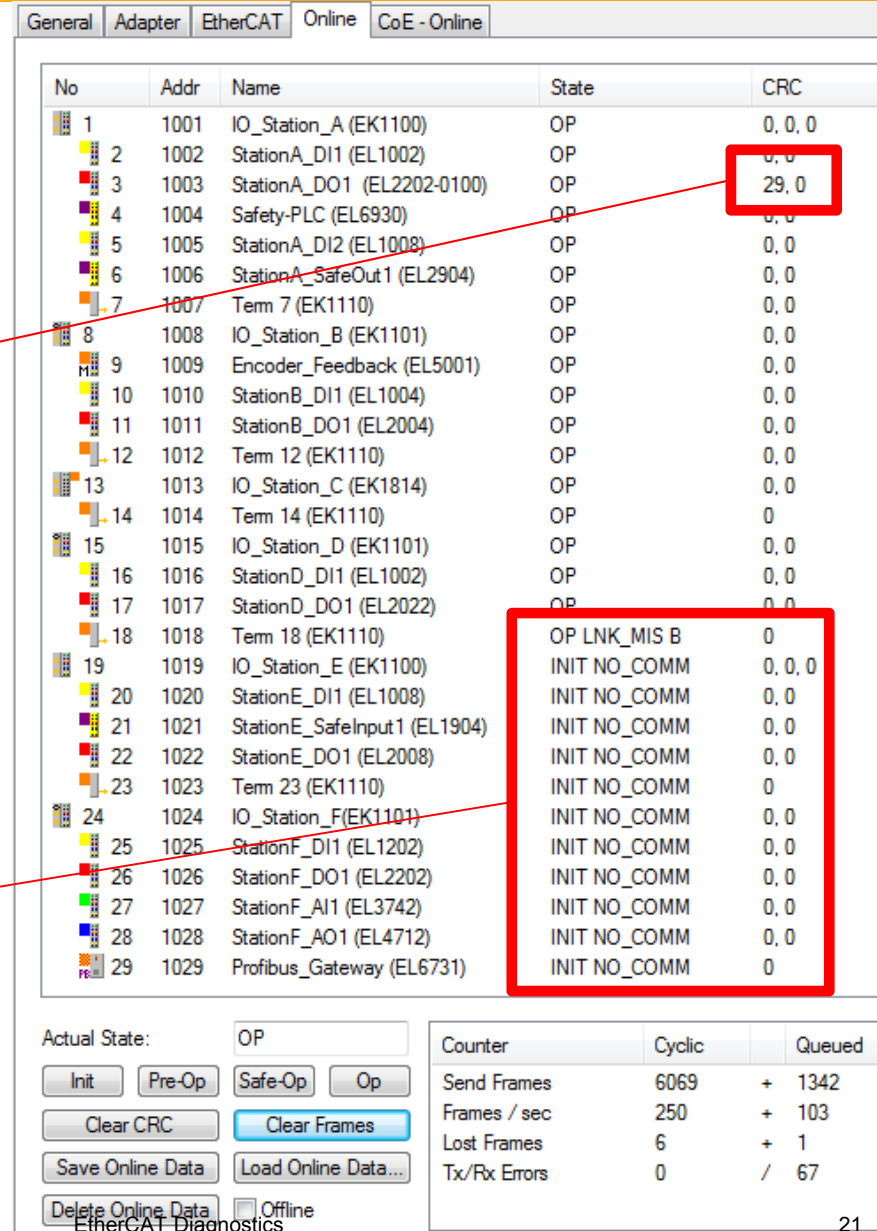

No	Addr	Name	State	CRC
1	1001	IO_Station_A (EK1100)	OP	0, 0, 0
2	1002	StationA_DI1 (EL1002)	OP	29, 0
3	1003	StationA_DO1 (EL2202-0100)	OP	0, 0
4	1004	Safety-PLC (EL6930)	OP	0, 0
5	1005	StationA_DI2 (EL1008)	OP	0, 0
6	1006	StationA_SafeOut1 (EL2904)	OP	0, 0
7	1007	Term 7 (EK1110)	OP	0, 0
8	1008	IO_Station_B (EK1101)	OP	0, 0
9	1009	Encoder_Feedback (EL5001)	OP	0, 0
10	1010	StationB_DI1 (EL1004)	OP	0, 0
11	1011	StationB_DO1 (EL2004)	OP	0, 0
12	1012	Term 12 (EK1110)	OP	0, 0
13	1013	IO_Station_C (EK1814)	OP	0, 0
14	1014	Term 14 (EK1110)	OP	0
15	1015	IO_Station_D (EK1101)	OP	0, 0
16	1016	StationD_DI1 (EL1002)	OP	0, 0
17	1017	StationD_DO1 (EL2022)	OP	0, 0
18	1018	Term 18 (EK1110)	OP	0
19	1019	IO_Station_E (EK1100)	OP LNK_MIS B	0
20	1020	StationE_DI1 (EL1008)	INIT NO_COMM	0, 0, 0
21	1021	StationE_SafeInput1 (EL1904)	INIT NO_COMM	0, 0
22	1022	StationE_DO1 (EL2008)	INIT NO_COMM	0, 0
23	1023	Term 23 (EK1110)	INIT NO_COMM	0
24	1024	IO_Station_F (EK1101)	INIT NO_COMM	0, 0
25	1025	StationF_DI1 (EL1202)	INIT NO_COMM	0, 0
26	1026	StationF_DO1 (EL2202)	INIT NO_COMM	0, 0
27	1027	StationF_AI1 (EL3742)	INIT NO_COMM	0, 0
28	1028	StationF_AO1 (EL4712)	INIT NO_COMM	0, 0
29	1029	Profibus_Gateway (EL6731)	INIT NO_COMM	0

Counter	Cyclic	Queued
Send Frames	6069	+ 1342
Frames / sec	250	+ 103
Lost Frames	6	+ 1
Tx/Rx Errors	0	/ 67

- Topology View can also be used for network overview

Example:  
Online Topology View

**Online Configuration**

All green – all in operational

EtherCAT	
Name:	Term 9 (EL5001)
Type:	EL5001
EtherCAT Addr:	1009
Auto Inc Addr:	FFF8
Identity	
Vendor Id:	2
Revision No:	0x03f90000
Product Code:	0x13893052
Serial No:	0x00000000
Product/Revision:	EL5001-0000-1017

- Topology View can also be used for network overview

Example:  
Online Topology View

The screenshot displays the 'Online Topology View' window. The main area shows a network diagram with several nodes connected by yellow lines. A red dot is visible on one of the nodes, with a red line pointing to it and the text 'Red dot - CRC error'. Another red line points to a node with a red status bar, labeled 'No Comm'. A legend on the right side of the diagram maps colors to operational states: Green for 'Op', Yellow for 'PreOp', Yel/Green for 'SafeOp', and Red for 'Init'. Below the diagram is a configuration panel for the selected node, 'Term 9 (EL5001)'. The panel includes fields for Name, Type, EtherCAT Addr, Auto Inc Addr, Vendor Id, Revision No, Product Code, Serial No, and Product/Revision.

**Online Configuration**

Green	Op
Yellow	PreOp
Yel/Green	SafeOp
Red	Init

No Comm

Red dot - CRC error

**EtherCAT Online Process Data**

Name: Term 9 (EL5001)

Type: EL5001

EtherCAT Addr: 1009

Auto Inc Addr: FFF8

Identity

Vendor Id: 2      Revision No: 0x03f90000

Product Code: 0x13893052      Serial No: 0x00000000

Product/Revision: EL5001-0000-1017

- EtherCAT State Machine (ESM) defines the operating states of each single Slave
- State Transitions to an upper state are requested by the Master
  - Master configures the slave according to the application settings and requests next state in AL Control
  - Slave checks the settings and confirms new state in AL Status
- Input and Output data are only valid in Operational state
- In case of errors the slave can
  - Refuse a state transition requested by the Master
  - Step spontaneously to a lower state
- The error is indicated in an Error flag and the error code is given in AL Status Code register

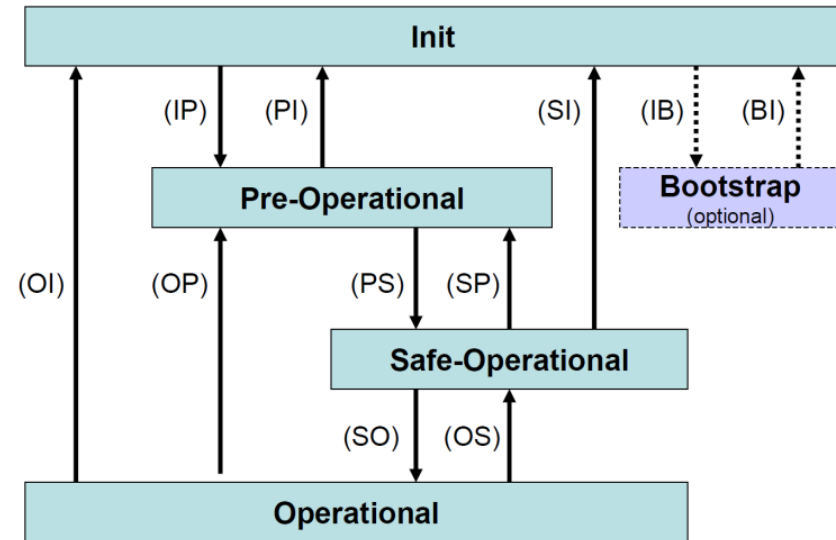

- Current state of the device is displayed at **RUN Indicator** on the device



State	RUN Indicator
Boot	Flickering
Init	Off
PreOp	Blinking
SafeOp	Flashing
Op	On

- Of course, the state information is also available in the master

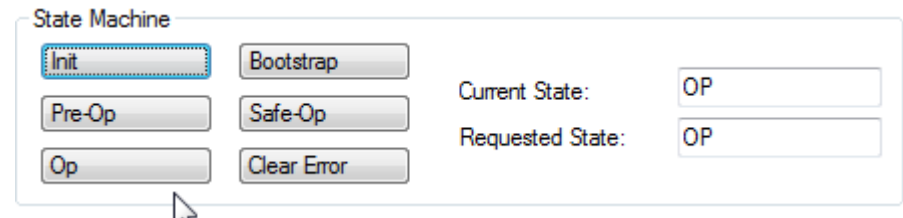

Setup

Operation

Maintenance

In case of an error...

- Each EtherCAT Datagram terminates with a **Working Counter**
  - This counter enables the Master to monitor the number of **successful memory interactions** of a specific Datagram with the Slaves addressed by the Datagram itself.

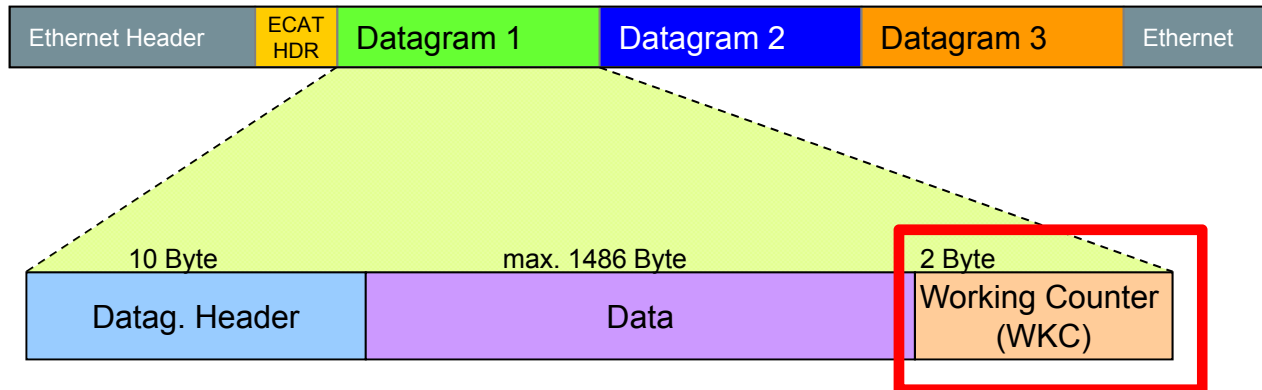

- Every slave increments the Working Counter in Hardware, if
  - Slave is addressed in Datagram Header
  - Addressed memory space is available to be read / written

# Purpose of EtherCAT Working Counter

- Monitor consistent update of data units, within each Cycle

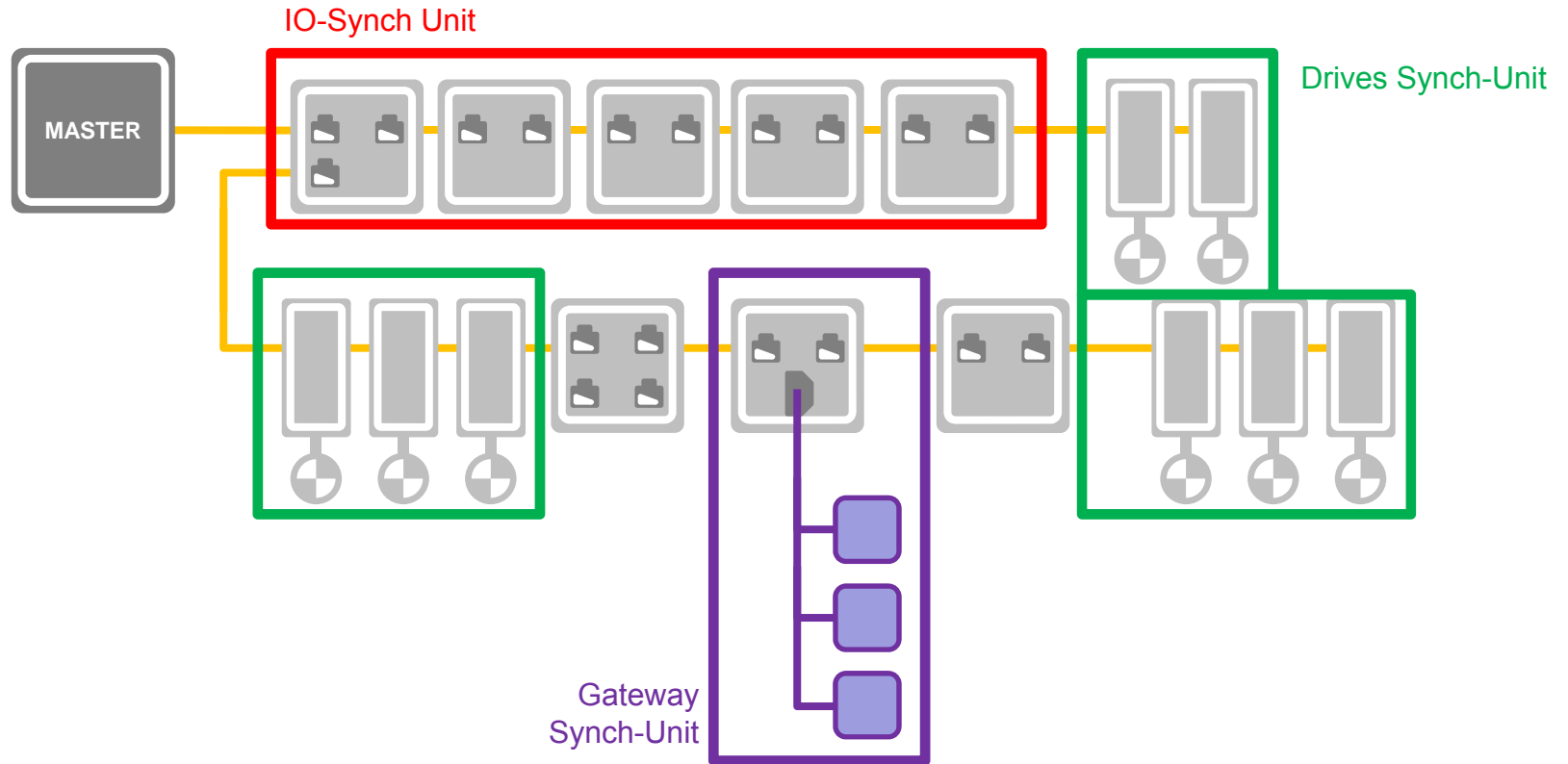

# Example: Check Op state of all slaves

- The Master can send a **BRD command** (broadcast read) as an additional datagram in the frame on AL Status register in each cycle



- Since each slave always supports the read access to this register, the received Working Counter reflects the **number of nodes** in the network
  - Missing nodes can be detected immediately in each cycle
- The data of the BRD command reflects the **states of the slaves**
  - The states are bit-coded in AL Status register
  - If all nodes are in Op state, only Bit 3 is set
  - If BRD data is  $\neq 8$ , at least one node is not in Op Master can start diagnosis process

AL Status 0x0130 Bit 3:0	Description
1 = 0001 <sub>b</sub>	Init State
2 = 0010 <sub>b</sub>	PreOp state
4 = 0100 <sub>b</sub>	SafeOp state
8 = 1000 <sub>b</sub>	Op state

# Maintenance cycle

Machine history,  
connection deterioration

Setup

Operation

Maintenance

In case of an error...

- Check history of the machine
- Check cabling

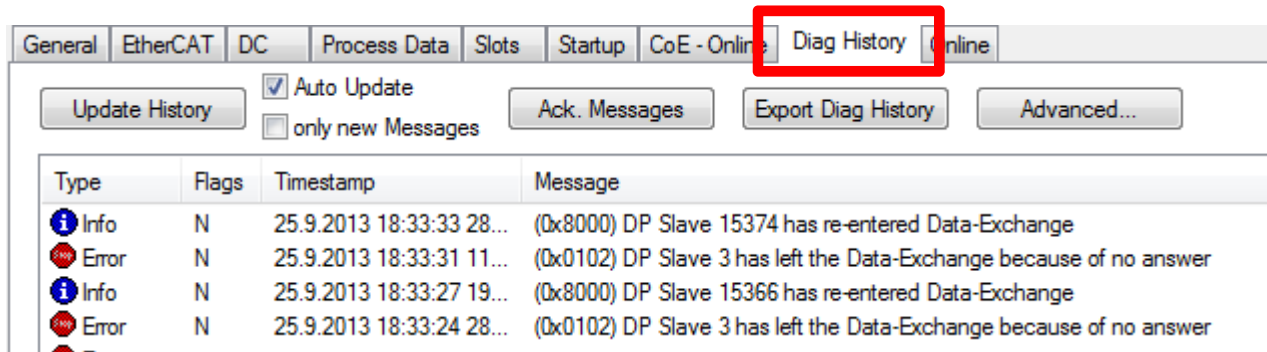

- **Diagnosis History Object** on slave can provide up to 249 Diagnosis Messages, with each containing
  - Diagnosis Code to identify the diagnosis message
  - Diag Type Info, Warning, Error
  - Text ID Reference to ESI File → Plain diagnosis message
  - Time Stamp sample time (optional)
- Single Bit „New Message available“ can be mapped into PDO to signal that new messages are available
- Advantage according to Emergency-Message:
  - Information is stored in the slave and can be read at any time, e.g. during inspection of machine Information can be read by Master Application, e.g. PLC program

- Each port of the ESC performs CRC evaluation of the incoming frame
- Rx Error Counter counts errors with wrong CRC
- If an RX error is detected, the frame is marked as corrupted, so that following slaves does not increment the Rx Error Counter  
→ Error localization is possible
- If an Rx Error Counter is increased it indicates that the electrical connection is disturbed. Possible reasons are
  - Bad shielding
  - Excessive noise
  - Loose connector
  - poor grounding

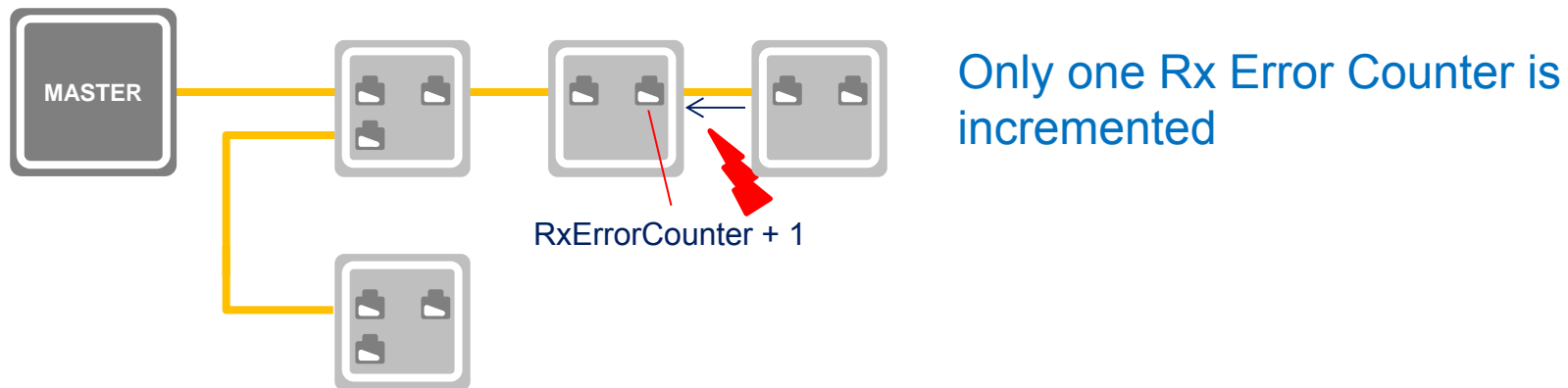

**In case of an error...**

**How to get the right information**

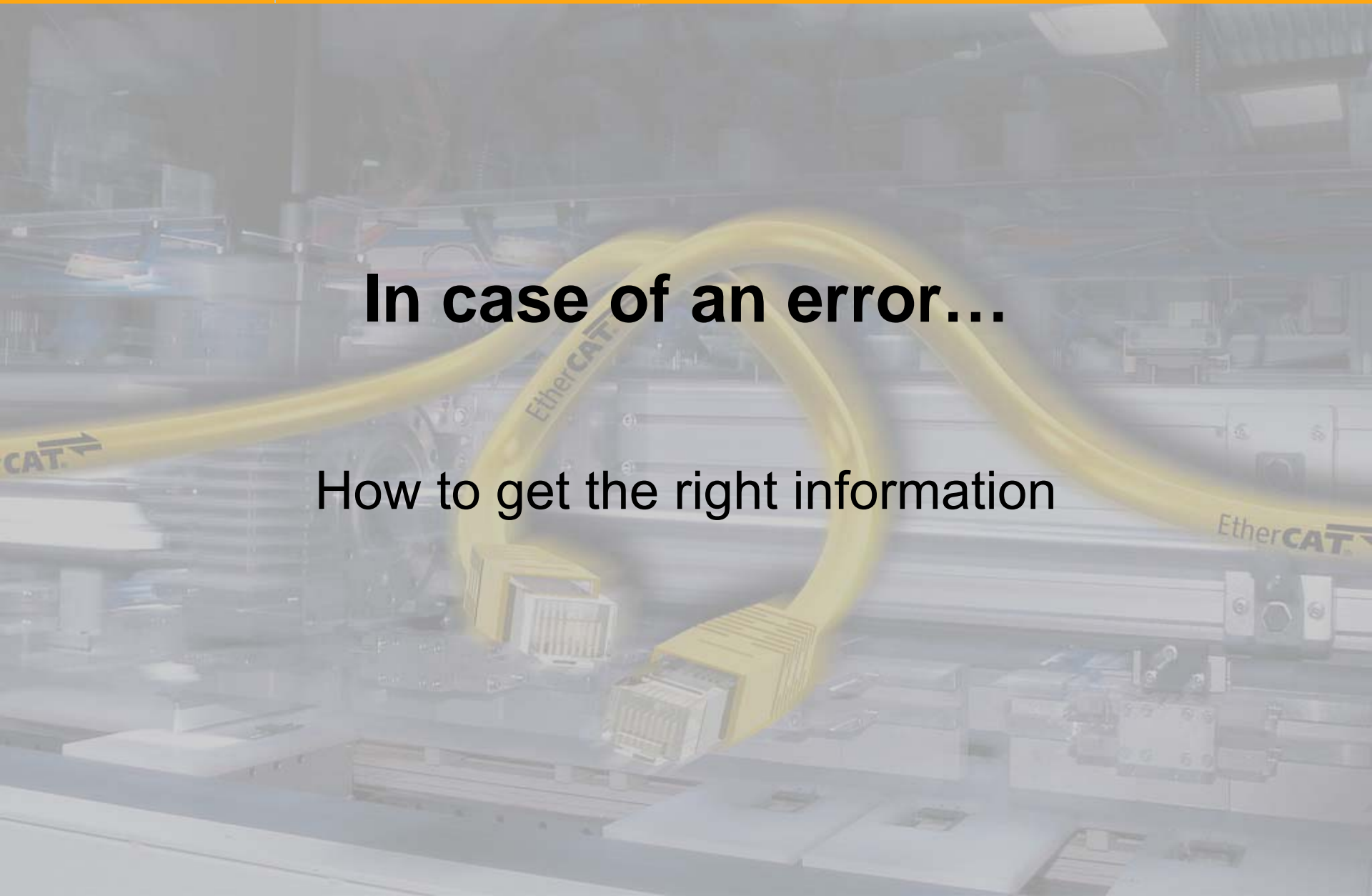

# In case of an error in a running machine...

Setup

Operation

Maintenance

In case of an error...

Next to the error indication, these questions need to be answered in case of error:

- **What** has happened?
- **Who** is affected?
- **Where** is it located?

Example scenario: Bad cable connection at device “Door\_DIO1”

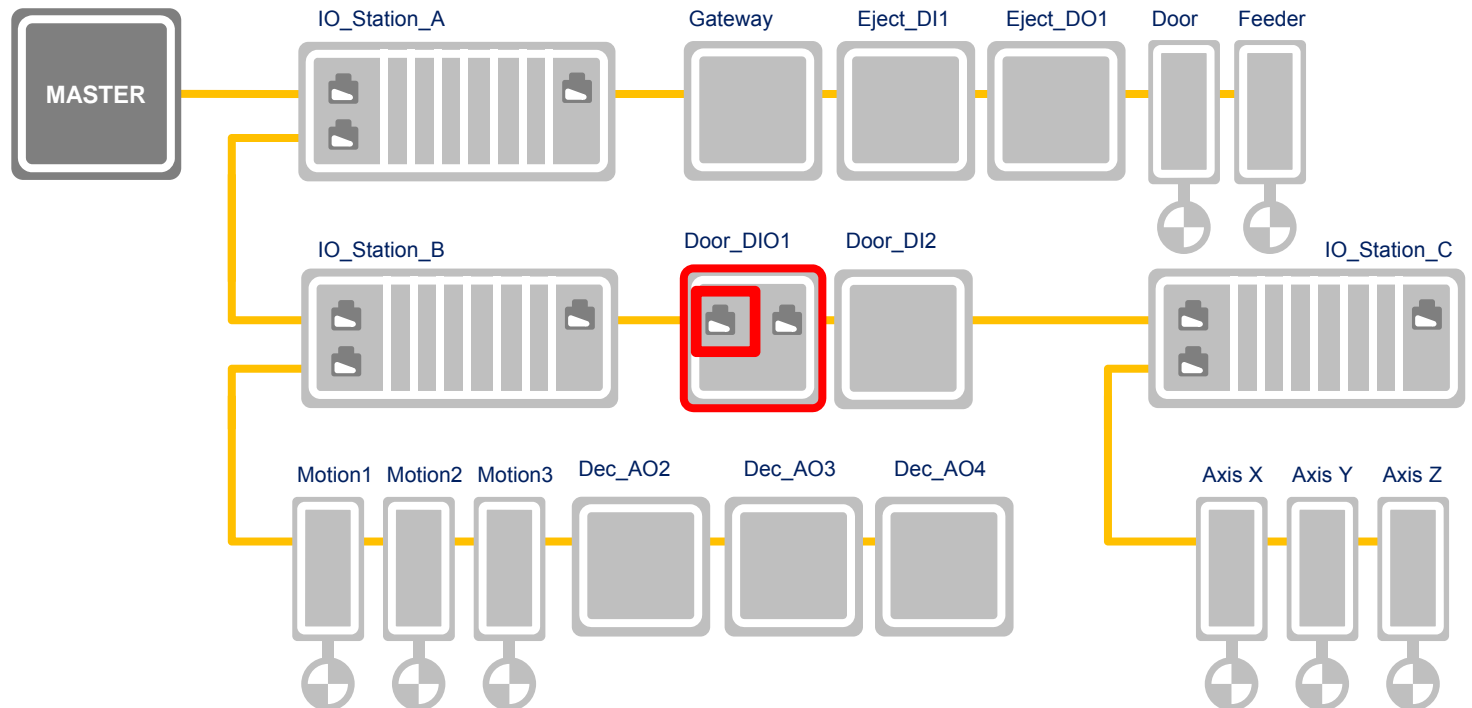

# Diagnosis Sequence

Setup  
Operation  
Maintenance

In case of an error...

## Bad cable connection at device "Door\_DIO1"

- Several CRC-Errors detected in slave *Door\_DIO1*  
→ Rx Error counter increments
- Slave detects input/output update error, since no data provided by ESC  
→ Slave steps back to SafeOp state and disables SyncManager

- LRW command including *Door\_DIO1* device:  
→ Master detects Working Counter error, since SyncManager is disabled  
→ Master discards Input data immediately
- Broadcast-Read command on AL Status:  
→ Master detects at least one slave not in OP

- Master reads AL Status register of all slaves  
→ slave *Door\_DIO1* not in OP

- Master reads AL Status Code register of *Door\_DIO1*  
→ Error reason: No valid inputs and outputs

- Master reads Error-Register set of slave *Door\_DIO1*  
→ Rx Error Counter of Port 0 (IN Port) incremented → **failure location**

Supervision



Error!

Slave *Door\_DIO1* not in Operational.

Error information No valid inputs and outputs

Possible reason Bad connection on IN-Port of the device.

Proposed action Please check cable or connector.

Example:  
Machine Overview

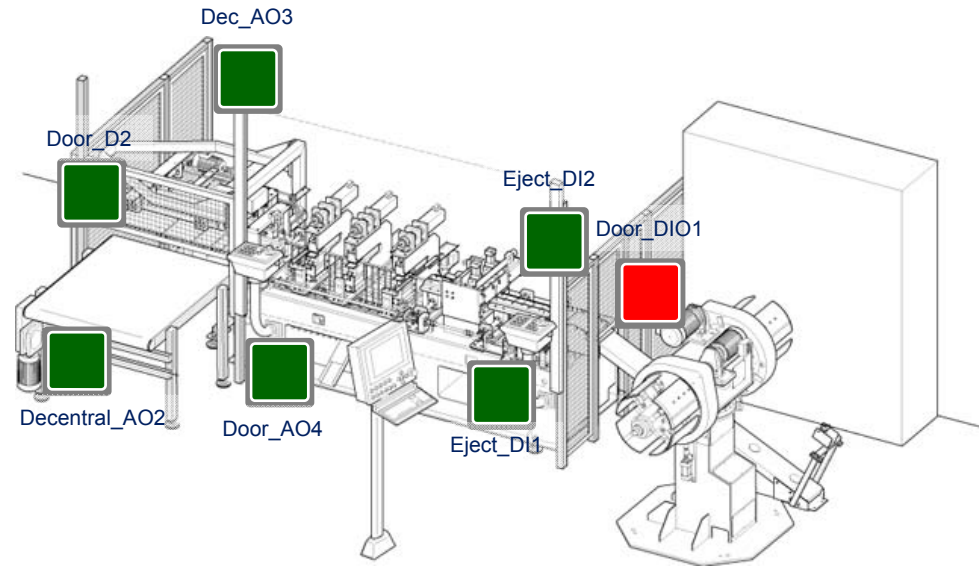
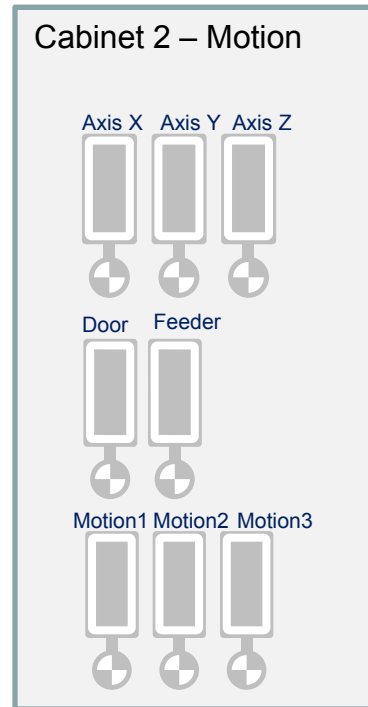
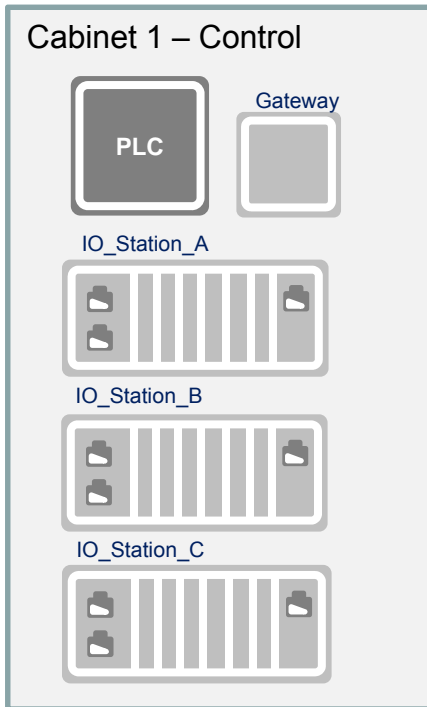

Setup  
Operation  
Maintenance

In case of an error...

- Topology view

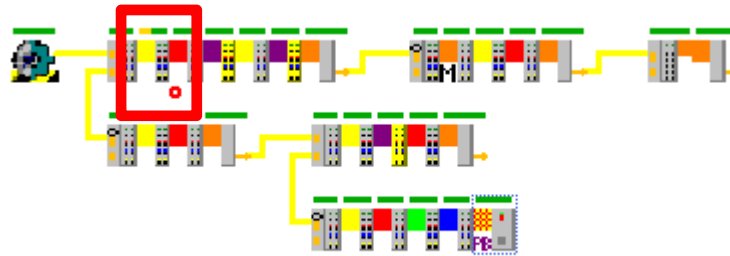

- Online view

No	Addr	Name	State	CRC
1	1001	IO_Station_A (EK1100)	OP	0.0.0
2	1002	StationA_DI1 (EL1002)	OP	0.0
3	1003	StationA_DO1 (EL2202-0100)	SAFEOP	29.0
4	1004	Safety-PLC (EL6930)	OP	0.0
5	1005	StationA_DI2 (EL1008)	OP	0.0
6	1006	StationA_SafeOut1 (EL2904)	OP	0.0
7	1007	Term 7 (EK1110)	OP	0.0
8	1008	IO_Station_B (EK1101)	OP	0.0
9	1009	Encoder_Feedback (EL5001)	OP	0.0
10	1010	StationB_DI1 (EL1004)	OP	0.0
11	1011	StationB_DO1 (EL2004)	OP	0.0
12	1012	Term 12 (EK1110)	OP	0.0
13	1013	IO_Station_C (EK1814)	OP	0.0
14	1014	Term 14 (EK1110)	OP	0
15	1015	IO_Station_D (EK1101)	OP	0.0
16	1016	StationD_DI1 (EL1002)	OP	0.0
17	1017	StationD_DO1 (EL2022)	OP	0.0

# QUESTIONS?