

EtherCAT[®] Installation Guideline

Guideline for Planning, Assembling and Commissioning of EtherCAT Networks

Document: ETG.1600 G (R) V1.0.3

Nomenclature:	
ETG-Number	ETG.1600
Type	G (Guide)
State	R (Release)
Version	V1.0.3

Created by:	EtherCAT Technology Group
Contact:	info@ethercat.org
Date:	2022-03-23

LEGAL NOTICE

Trademarks and Patents

EtherCAT® and Safety over EtherCAT® are registered trademarks and patented technologies, licensed by Beckhoff Automation GmbH, Germany. Other designations used in this publication may be trademarks whose use by third parties for their own purposes could violate the rights of the owners.

Disclaimer

The documentation has been prepared with care. The technology described is, however, constantly under development. For that reason the documentation is not in every case checked for consistency with performance data, standards or other characteristics. In the event that it contains technical or editorial errors, we retain the right to make alterations at any time and without warning. No claims for the modification of products that have already been supplied may be made on the basis of the data, diagrams and descriptions in this documentation.

Copyright

© EtherCAT Technology Group.

The reproduction, distribution and utilization of this document as well as the communication of its contents to others without express authorization is prohibited. Offenders will be held liable for the payment of damages. All rights reserved in the event of the grant of a patent, utility model or design.
www.ethercat.org

DOCUMENT HISTORY

Version	Comment
1.0.0	First Release
1.0.1	Capacitance values corrected in Figures 14 and 25
1.0.2	Notes added to Table 12
1.0.3	Clause 4.2 adapted. Clause 5.4.2 and Table 10 updated. Clause 5.8 text adapted. Clause 6.4 extended with M8 connectors. Clause 7.4 name of hardware error counters adapted to ETG.1000 specification.

CONTENTS

1	Foreword and Scope	1
2	References	2
3	Terms, Definitions and Word Usage	3
	3.1 Terms and Definitions	3
	3.2 Word usage: shall, should, may, can	3
4	EtherCAT Basics	4
	4.1 Network Configuration	4
	4.2 Physical Media	4
	4.3 Topologies	5
	4.4 Link Detection and Frame Routing	6
	4.5 On-the-fly Processing	8
5	Planning	9
	5.1 Environmental Conditions	9
	5.2 Topology Definition and Device Positioning	9
	5.3 Channel Dimensioning	10
	5.3.1 Channel Parameters for 100BASE-TX Link	11
	5.3.2 Channel Parameters for 100BASE-FX Link	16
	5.4 Cable Selection	17
	5.4.1 Cables for 100BASE-TX Link	18
	5.4.2 Cables for 100BASE-FX Link	25
	5.5 Connector Selection	25
	5.6 Cable Separation	26
	5.7 Earthing and Grounding	28
	5.7.1 Equipotential Earthing	28
	5.7.2 Star Earthing	28
	5.8 Selection of Infrastructural Components	30
	5.9 Selection of EtherCAT Slave Devices	32
	5.10 Additional Tasks in the Planning Phase	32
6	Assembling	34
	6.1 General Procedures for Assembling	34
	6.2 Electromagnetic Protection	34
	6.3 Mechanical Protection	39
	6.4 Connector Assembling	44
	6.4.1 Assembly of RJ45 Connectors	44
	6.4.2 Assembly of M12 and M8 Connectors	46
7	Commissioning	51
	7.1 Visual Check	51
	7.2 Measurement of Channel Physical Parameters	52
	7.2.1 Cable Testing	52
	7.2.2 Function Testing	53
	7.2.3 Acceptance Testing	54
	7.2.4 Checklist for Channel Measurements	56
	7.3 Measurement of Earthing System	56
	7.4 EtherCAT-Specific Diagnostics	57
	7.4.1 Lost Link Counters	57
	7.4.2 Physical Layer Error Counters	58
	7.4.3 Frame Error Counters	59
8	Summary	60

TABLES

Table 1: parameters for copper channel	11
Table 2: Reference parameters for a Class D channel of 100m length	13
Table 3: reference parameters for fiber optic channel	16
Table 4: reference parameters for fixed cables used for permanent link	18
Table 5: reference parameters for flexible cables used for permanent link	19
Table 6: example of cable used for permanent link.....	20
Table 7: examples of cable shield coding	22
Table 8: correspondence between conductor diameter and AWG coding.....	24
Table 9: reference parameters for fiber optic cables.....	25
Table 10: standard connectors for copper cables	26
Table 11: standard connectors for fiber optic cables	26
Table 12: reference values for minimum distance between communication and power cables	27
Table 13: relation between cross section and length of earthing wires	30
Table 14: possible additional tasks in the planning phase	33
Table 15: wire color correspondence between ISO 61918 and TIA-568-C	48
Table 16: checklist for network visual inspection	51
Table 17: checklist for channel measurements	56
Table 18: checklist for earthing system	57
Table 19: Lost Link Counter registers	58
Table 20: Physical Layer Error Counter registers	58
Table 21: Frame Error Counter registers	59

FIGURES

Figure 1: number of slaves on an EtherCAT network	4
Figure 2: EtherCAT physical media.....	5
Figure 3: EtherCAT topologies	5
Figure 4: internal port structure in ESC	6
Figure 5: physical link establishment.....	7
Figure 6: port status and physical link	7
Figure 7: EtherCAT frame routing	8
Figure 8: on-the-fly processing in ESC.....	8
Figure 9: channel and end-to-end link structure.....	10
Figure 10: several possible channel architectures	12
Figure 11: physical meaning of IL and NEXT parameters	14
Figure 12: counting the number of connections	15
Figure 13: difference between fixed and flexible cables	19
Figure 14: proper termination of unused pairs within a device.....	21
Figure 15: recommended and discouraged shielding configurations.....	23
Figure 16: minimum distance between communication and power cables	27
Figure 17: minimum distance with metallic separation conduits	27
Figure 18: equipotential earthing scheme	28
Figure 19: star earthing scheme.....	29
Figure 20: behavior in case of active infrastructure component.....	31
Figure 21: integration of ESC within active infrastructural components.....	32
Figure 22: crossing between communication and power cables.....	34
Figure 23: avoiding loops in communication cables.....	34
Figure 24: shield-to-earth connection options within a device	35
Figure 25: internal RC connection to earth within devices	35
Figure 26: measurement of shield earthing within devices	36
Figure 27: external earthing of the cable shield via cable clips	37
Figure 28: proper and improper size of cable clips	37
Figure 29: proper and improper shield handling at earthing point.....	38
Figure 30: external earthing of the cable shield via metal foils	38
Figure 31: proper earthing of bulkhead feed-through connectors	39
Figure 32: maintaining the minimum bending radius of communication cables.....	40
Figure 33: protection of sharp edges along the path of communication cables.....	40
Figure 34: tensile forces acting on communication cables.....	41

Figure 35: protecting communication cables against tensile forces.....	41
Figure 36: proper and improper dimensioning of strain relief components.....	42
Figure 37: torsional forces acting on communication cables	42
Figure 38: protect communication cables against crushing	43
Figure 39: connector pinout assignment for quad cables, according to ISO/IEC 61918	44
Figure 40: cabling schemes for RJ45 connectors according to TIA-568-C.....	48
Figure 41: badly assembled RJ45 connector	49
Figure 42: proper and improper connection of cable shield with connector housing.....	50
Figure 43: simple cable verification with a multimeter device	53
Figure 44: cable qualification with a function tester device	54
Figure 45: cable certification with an acceptance tester	54
Figure 46: parameter measurement for infrastructural components.....	55

ABBREVIATIONS

μC	Microcontroller
ACR	Attenuation-to-crosstalk ratio
ANSI	American National Standards Institute
AWG	American Wire Gauge
BN	Brown
BU	Blue
CP	Communication Profile
CRC	Cyclic Redundancy Check
DPRAM	Dual-Ported RAM
EM	Electro-magnetic
EN	European standard
ESC	EtherCAT Slave Controller
ETG	EtherCAT Technology Group
GN	Green
IEC	International Electrotechnical Commission
IL	Insertion Loss
ISO	International Organization for Standardization
LLF	Link Lost Forwarding
LVDS	Low Voltage Differential Signal
MAC	Media Access Controller
NEXT	Near-end crosstalk
NIC	Network Interface Card
OG	Orange
PHY	Physical Layer Chip
RJ45	Registered Jack 45
RL	Return Loss
SC	Subscriber Connector
TIA	Telecommunications Industry Association
TP	Twisted Pair
TQ	Twisted Quad
WH	White
YE	Yellow

1 Foreword and Scope

The selected communication technology has several advantages compared to the traditional fieldbuses with passive wiring infrastructure, and proven on the field in a huge number of commercial and industrial implementations. The recommended cabling improves the signal to noise ratio by an order of magnitude.

The better immunity to EM noise finds its explanation in the peer-to-peer relationship of the Ethernet transmission technology, as well as in the use of shielded cables. These measures isolate errors on a specific link and allow better adaption of the receiver to the sender. A permanent link monitoring helps to detect erroneous components at runtime without delays.

EtherCAT components have link active indicators. Thus, a problem in the wiring can be quickly identified even without specific tools. The master can make use of the error counters built in the EtherCAT Slaves and react quickly to any deviation from normal behavior.

Hence, there is no need for expensive cable diagnostic or sophisticated test procedures in general. But some measures can help to avoid problems caused by misconfiguration, errors in cable installation and critical environmental conditions.

The information collected in this document guides to find the right tradeoff between additional effort and enhanced reliability of a specific automation system in regards to cable installation.

This document is structured into four main sections, each with a specific scope:

- **EtherCAT Basics:** provides a short description of technical features which are relevant for the understanding of EtherCAT networks.
- **Planning:** is intended to support engineers which plan an industrial communication network based on the EtherCAT technology, with specific reference to international standards.
- **Assembling:** is intended to support technicians which realize the EtherCAT communication network based on a previous plan.
- **Commissioning:** is intended to support technicians, as well as end users, which check the correctness of an installation, or monitor the operation of an industrial communication network based on the EtherCAT technology.

This document is not a specification, nor does it replace other ETG documents. It is intended to provide practical information concerning the installation of an EtherCAT network, and it complements the ETG specification documents.

This document does not claim to fully describe the EtherCAT technology. It describes those aspects which may influence the network implementation or performances. For a complete information about the EtherCAT technology, refer to the specifications and documents provided by the EtherCAT Technology Group and which are related to the EtherCAT standard.

2 References

The following referenced documents are indispensable for the application of this document. For dated references, only the edition cited applies. For undated references, the latest edition of the referenced document (including any amendments) applies.

ETG Standards

- [1] ETG.1000.2: Physical Layer service definition and protocol specification
- [2] ETG.1000.3: Data Link Layer service definition
- [3] ETG.1000.4: Data Link Layer protocol specification
- [4] ETG.1000.5: Application Layer service definition
- [5] ETG.1000.6: Application Layer protocol specification

Other References

- [6] ISO/IEC 61918: Industrial communication networks – Installation of communication networks in industrial premises
- [7] ISO/IEC 61784-5-12: Industrial communication networks – Profiles – Part 5-12: Installation of fieldbuses – Installation profiles for CPF 12
- [8] ISO/IEC 11801: Information technology – Generic cabling for customer premises
- [9] IEC 61076-2-101: Connectors for electronic equipment - Product requirements - Part 2-101: Circular connectors - Detail specification for M12 connectors with screw-locking
- [10] IEC 61754-4: Fibre optic interconnecting devices and passive components - Fibre optic connector interfaces - Part 4: Type SC connector family
- [11] IEC 61754-24: Fibre optic interconnecting devices and passive components - Fibre optic connector interfaces - Part 24: Type SC-RJ connector family
- [12] IEC 60603-7-3: Connectors for electronic equipment - Part 7-3: Detail specification for 8-way, shielded, free and fixed connectors, for data transmission with frequencies up to 100 MHz
- [13] EN 50174-2: Cabling installation – Part 2: Installation planning and practices inside buildings
- [14] EN50288-2-1: Multi-element metallic cables used in analogue and digital communication and control - Part 2-1: Sectional specification for screened cables characterised up to 100 MHz - Horizontal and building backbone cables
- [15] EN50288-2-2: Multi-element metallic cables used in analogue and digital communication and control - Part 2-2: Sectional specification for screened cables characterised up to 100 MHz - Work area and patch cord cables
- [16] EN60793-2-10: Optical fibres - Part 2-10: Product specifications - Sectional specification for category A1 multimode fibre
- [17] EN60793-2-50: Optical fibres - Part 2-50: Product specifications - Sectional specification for class B single-mode fibres
- [18] ANSI/TIA-568-C: Generic telecommunication cabling for customer premises

3 Terms, Definitions and Word Usage

3.1 Terms and Definitions

The terms and definitions of ETG.1000 series shall be fully valid, unless otherwise stated.

3.2 Word usage: shall, should, may, can

The word *shall* is used to indicate mandatory requirements strictly to be followed in order to conform to the standard and from which no deviation is permitted (*shall* equals *is required to*).

The word *should* is used to indicate that among several possibilities one is recommended as particularly suitable, without mentioning or excluding others; or that a certain course of action is preferred but not necessarily required; or that (in the negative form) a certain course of action is deprecated but not prohibited (*should* equals *is recommended that*).

The word *may* is used to indicate a course of action permissible within the limits of the standard (*may* equals *is permitted to*).

The word *can* is used for statements of possibility and capability, whether material, physical, or causal (*can* equals *is able to*).

4 EtherCAT Basics

4.1 Network Configuration

An EtherCAT network consists of one master, and one or more slave devices.

- On master side, standard network adapters can be used at hardware level
- On slave side, low-level time-critical functionalities are implemented in a dedicated hardware component called EtherCAT Slave Controller (ESC)

Slave devices are addressed by a 16-bit address field, therefore the number of slaves connected to the EtherCAT network can theoretically reach 65535 devices (Figure 1).



Figure 1: number of slaves on an EtherCAT network

4.2 Physical Media

EtherCAT supports two different physical media:

- 100BASE-TX, 100 Mbit/s full-duplex transmission on copper cable (up to 100 m distances)
- 100BASE-FX, 100 Mbit/s full-duplex transmission on fiber optics (up to several km distances)

Some ESCs also support a LVDS-based physical medium according to ANSI/TIA/EIA-644 for 100 Mbit/s, full-duplex transmission on very short backplane connections (e.g. in modular I/O systems).

There is no limitation in the number of changes of physical medium within the network (as shown in Figure 2).

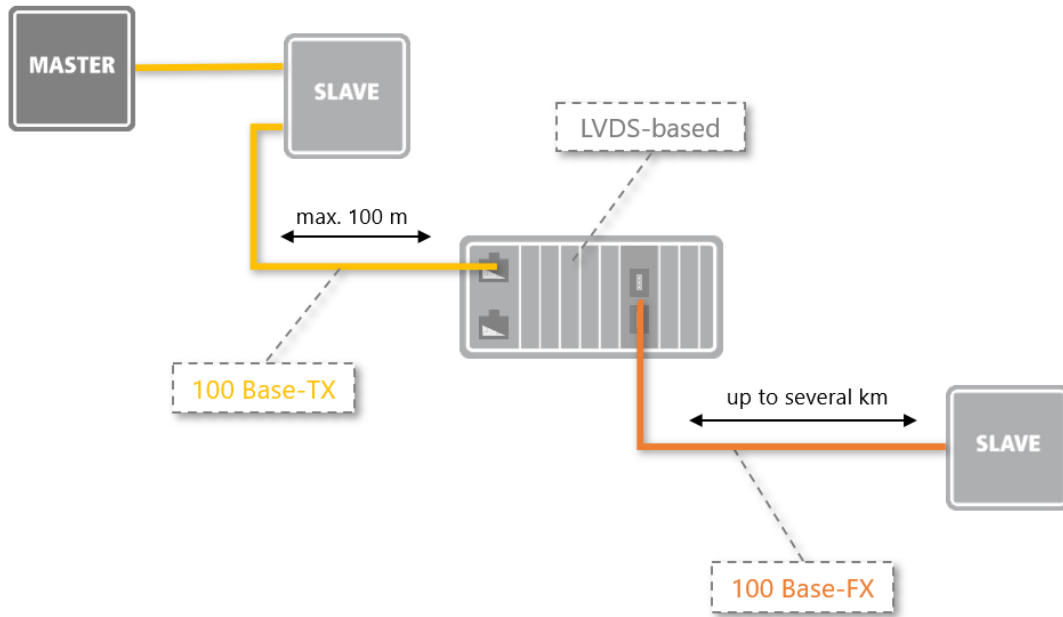

Figure 2: EtherCAT physical media

4.3 Topologies

EtherCAT allows to implement several topologies, like line, daisy-chain, star or tree (Figure 3).

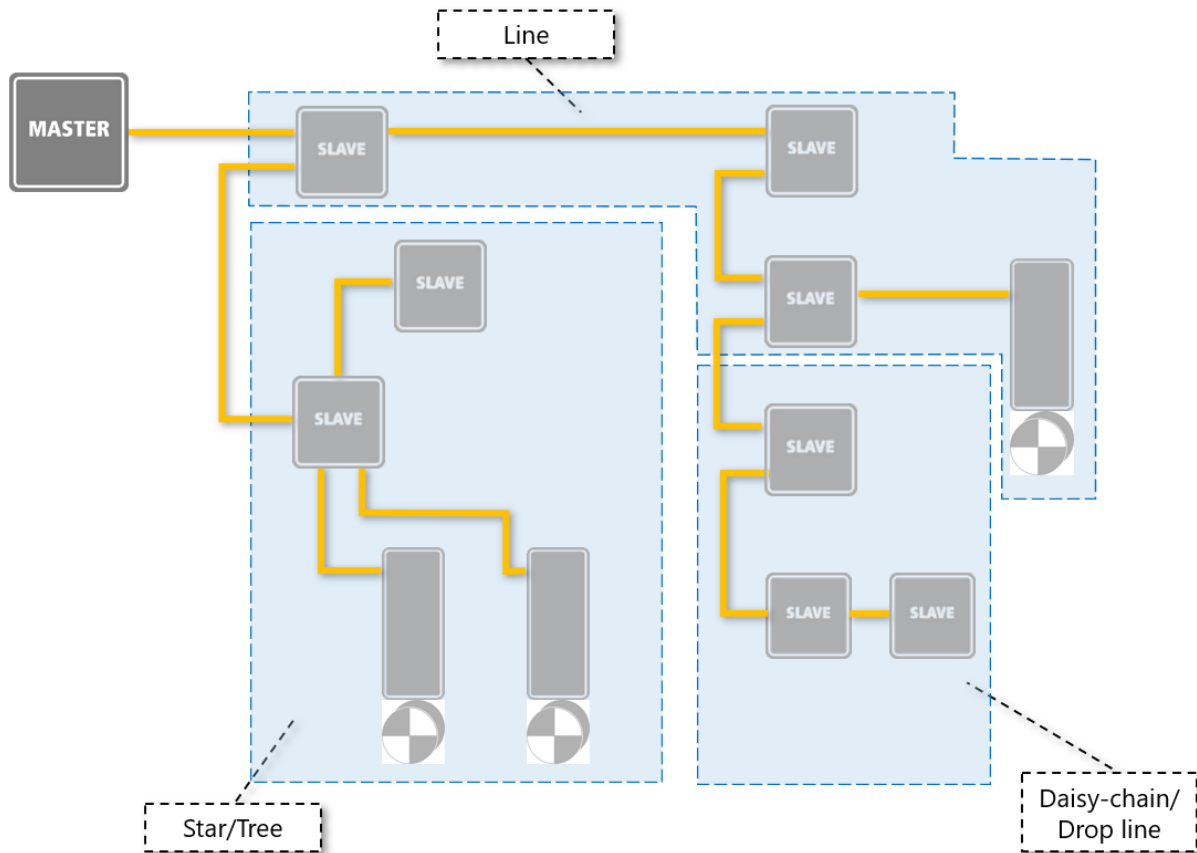

Figure 3: EtherCAT topologies

Network performances like synchronization degree, propagation and processing delays, or minimum cycle times, are independent from the specific topology scheme.

4.4 Link Detection and Frame Routing

ESCs internally support up to four communication ports, ring-wise connected to each other (as shown in Figure 4):

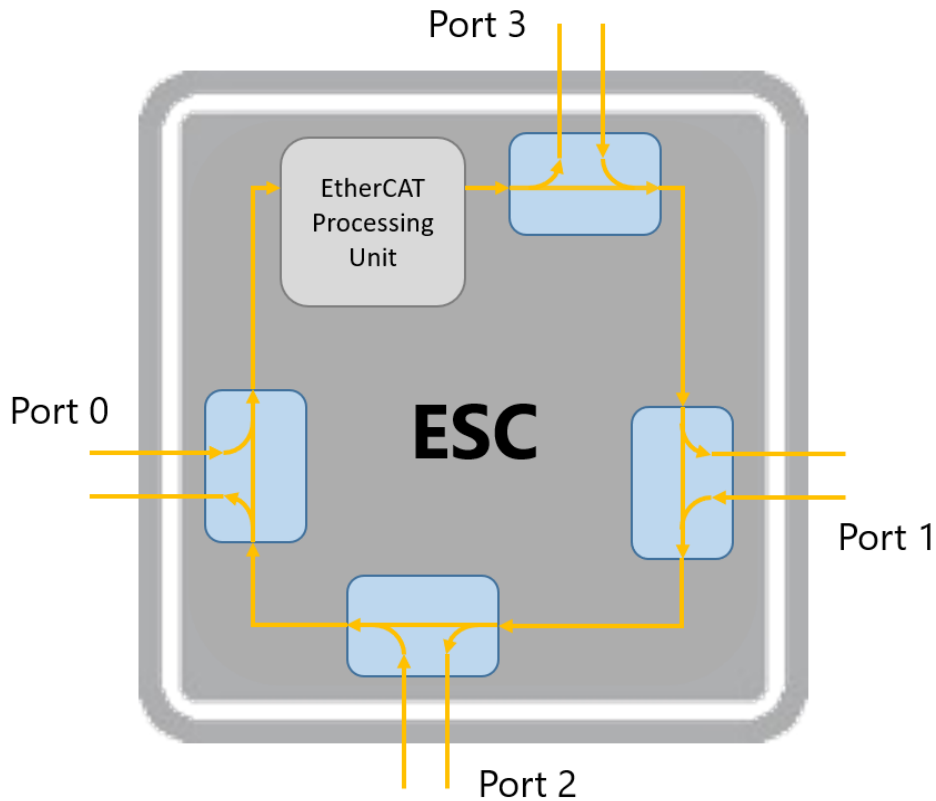

Figure 4: internal port structure in ESC

After a power-on or a reset, according to the existing connections between slaves, a port is opened if a physical link to another device is detected, while it remains closed if no physical link is present: the network topology is therefore automatically built-up by slave devices at hardware level.

A physical link between two devices can be considered as established when, despite all causes which can corrupt the electrical signals (like attenuation, reflections, EMC disturbances), both devices are able to correctly recover the received symbol sequences (Figure 5).

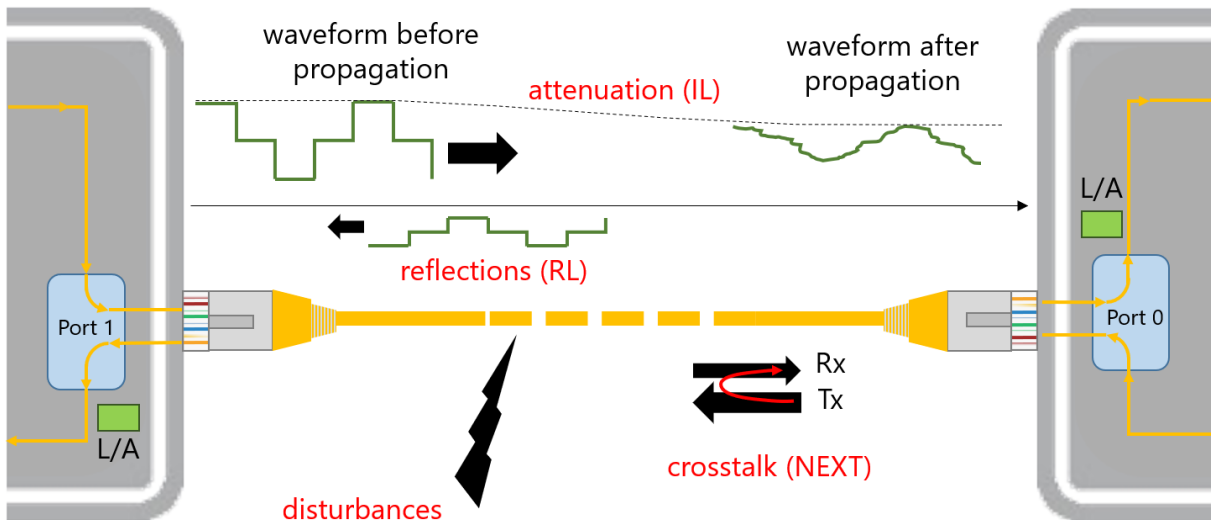

Figure 5: physical link establishment

All slave ports with removable connectors are mandatorily provided with link/activity (L/A) LEDs, which describes the physical link status:

- L/A LED off: no physical link is present
- L/A LED on: physical link is present, but no network traffic
- L/A LED flickering: physical link is present, with network traffic

Figure 6 shows two examples of the relation between hardware connections and link status in a slave device.

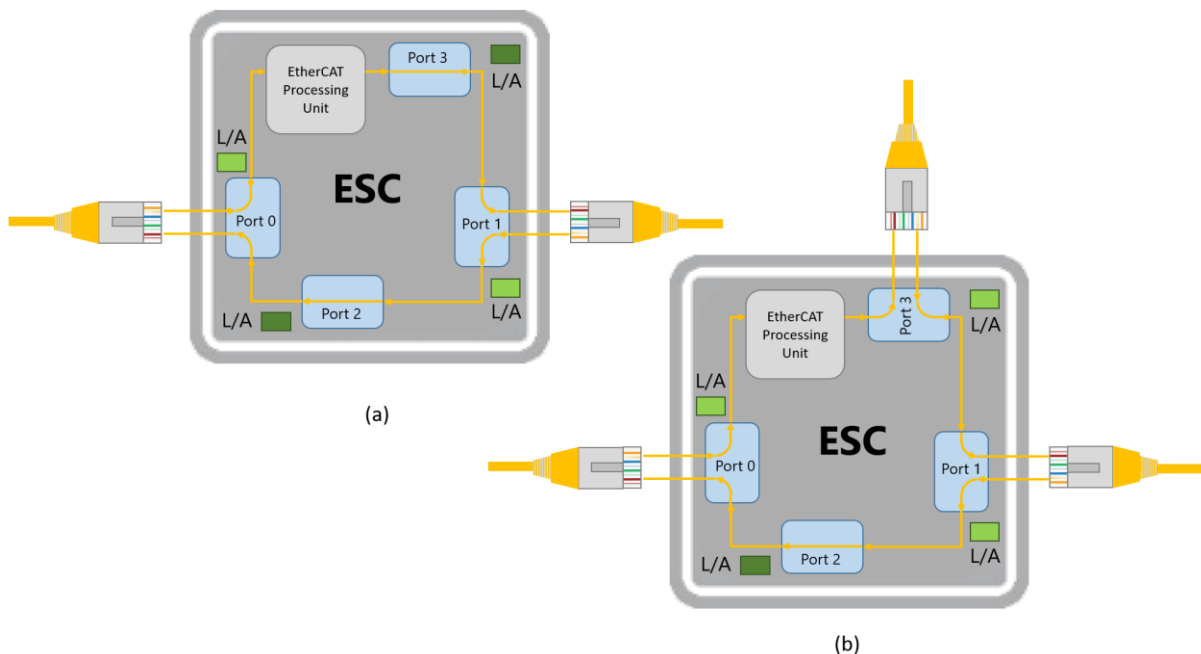

Figure 6: port status and physical link

The internal ESC architecture ensures that, independently from the specific topology, the network always operates according to a logical loop principle: frames sent by the master are routed from slave to slave in a predefined order - determined only by the hardware connections among ports and without any software addressing mechanism – and then return to the master, as shown in Figure 7.

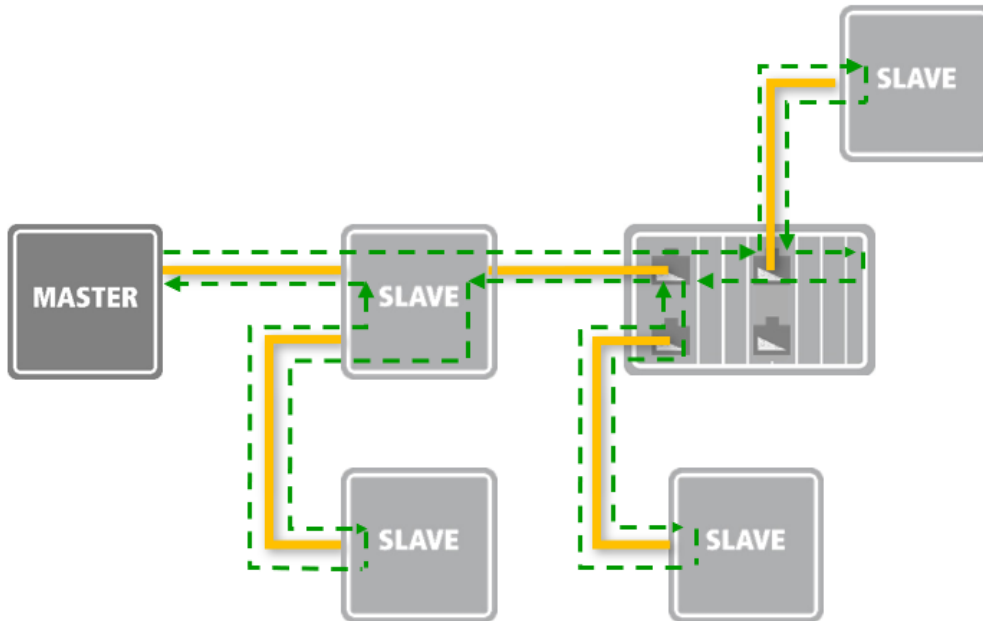

Figure 7: EtherCAT frame routing

4.5 On-the-fly Processing

When propagating through ESCs, frames are processed “on-the-fly”: single bits or entire byte sequences are dynamically extracted from, and inserted into the frames by the so-called EtherCAT Processing Unit without the need to store and process the whole frame content (as shown in Figure 8). The hardware propagation delays on the network are therefore not affected by the processing time of the software stack. Typical values for the sum of propagation delays in both directions within each ESC are:

- ~ 1 μ s, for slaves supporting at least one 100BASE-TX or 100BASE-FX port
- ~ 300 ns, for slaves supporting only LVDS ports

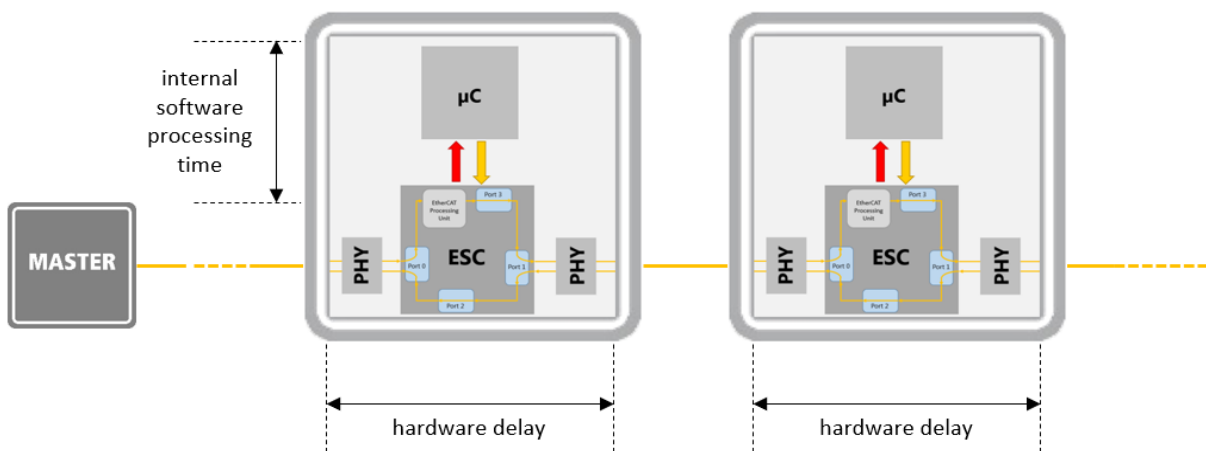

Figure 8: on-the-fly processing in ESC

5 Planning

Scope of planning of the communication infrastructure within a machine or plant should be to define in advance all those implementation aspects which are recommended to ensure an error-free data transmission between devices under all operating conditions. The result of the planning phase should be a list of all the interconnections between devices. For each interconnection, all relevant aspects should be reported, like desired cable routing, critical wiring aspects and a set of actions required to ensure a certain communication quality level. Component lists, checklists and test plans could be an additional output of the planning phase.

5.1 Environmental Conditions

For the planning of the communication infrastructure, a precise knowledge of the environmental conditions in the machine or plant is required. Relevant aspects are:

- Layout of the cabling, length, bending and cable type
- Connectors, media converters and infrastructural components in the transmission path
- Electromagnetic conditions, determined by the presence of power cables, motors, power electronics, light sources, radio-frequency transmitters
- Mechanical constraints like moving parts, rotating components, tension forces, vibrations, shocks
- Maximum and minimum operating temperature values
- Chemical environment like presence of water, dust, or corrosive agents

It may be useful to classify some of the environmental conditions, for example with the help of the MICE (Mechanical, Ingress, Climatic and Electromagnetic) model described in the IEC 61918 standard. These environmental conditions should be kept in mind during the whole planning process, as they will influence the component choice as well as the cable routing or the adoption of measures to ensure transmission quality.

Examples of specific actions which could be performed during the planning phase, according to the specific environmental conditions, are the following:

- Check the total length of the cable traces
- Recognize critical EM environments, and plan adequate protection accordingly
- Check the allowed temperature range of all components (including cables) against the environmental conditions
- Select the appropriate IP protection level for devices
- Select the appropriate IP protection level for connectors
- Use adequate cable entry systems to protect against dust, dirt and liquids.
- Check suitable protection against dangerous liquids.
- Avoid cable mechanical stress which would be outside the maximum tolerated values, and plan adequate protection accordingly
- Provide absorption of vibrations whenever possible
- In case of outdoor applications, consider the use of UV-resistant cables or protection shields
- In case of underground traces or moving parts, consider the use of specifically designed cables

5.2 Topology Definition and Device Positioning

As described in Subclause 4.3, the performances of an EtherCAT network are not influenced by the specific network topology adopted.

There is no limitation, for example, in the number of devices which can be cascaded in a line or daisy-chain topology. The only remark concerning line or daisy-chain topologies is that, if a device is powered-off or disconnected from the network and no cable redundancy is supported, the downstream devices will also no more be reached by frames: in case the application requires slaves, or groups of slaves, to be powered off or disconnected independently from the rest of the network, a star topology should therefore be preferred.

For this reasons, the network topology should be uniquely planned with the aim of minimizing the length of communication cables, compatibly with those requirements which are necessary to guarantee an

error-free communication (like keeping a suitable distance from EM noise sources or protecting cables against mechanical damage or chemical agents).

The device positioning and commissioning should always be performed according to the specific information and mounting rules provided by device manufacturers, and according to the specific environmental conditions as described in Subclause 5.1.

5.3 Channel Dimensioning

In addition to environmental conditions, the performance of hardware connections between devices can be influenced by factors like:

- Cable quality (attenuation, number of conductors, crosstalk, shielding)
- Connector quality (correct pinout assignment, proper connection to cable shield)
- Intermediate connections (number of intermediate transitions, attenuation)

These aspects can be evaluated and properly taken into account during the planning phase thanks to the concept of structured cabling, as described in the ISO/IEC 11801 specification. The scope of structured cabling is to define a standard, application-independent model for the hardware connection between two network devices. According to the maximum communication bit-rate that shall be supported, several link performance classes can be defined. Each class is described in terms of the physical link parameters, and defines for them worst-case corner values which should ensure an error-free data transmission under all operating conditions.

The structured cabling model defined in the ISO/IEC 11801 specification is based on the concepts of “channel” and “end-to-end link”, as described in Figure 9:

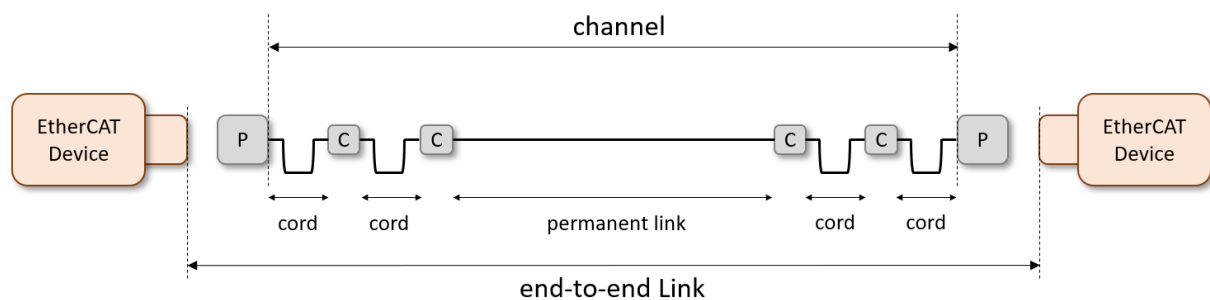

Figure 9: channel and end-to-end link structure

In this model:

- J are the jacks in the end devices
- P the plugs at the connection ends
- C the intermediate connectors.

The “end-to-end link” concept includes the two plugs at the connection ends (yet not the jacks of the end devices), while the “channel” concept does not include them.

According to the channel model, cables employed in the connection between two end devices can be distinguished into:

- Permanent link, the main cable span between two end devices, installed either within or outside the cabinet
- (Patch) cords, typically short cable sections used within a cabinet between end devices and intermediate connection points (like bulkhead feed-through connectors).

The ISO/IEC 61918 specification applies the generic channel model defined in the ISO/IEC 11801 to industrial communication networks, while the ISO/IEC 61784-5-12 profile defines the EtherCAT requirements to this model.

5.3.1 Channel Parameters for 100BASE-TX Link

Table 1: parameters for copper channel

Characteristics	Value
Supported data rates (Mbit/s)	100
Supported max. channel length (m)	100
Number of connections in the channel (max.)	6
Channel class per ISO/IEC 24702 (min.)	D
Cable category per ISO/IEC 24702 (min.)	5
Connecting HW category per ISO/IEC 24702 (min.)	5

The ISO/IEC 11801 specification defines mathematical rules for a precise calculation of the maximum channel length as a function of the number of intermediate connections and of copper cable physical parameters. In the planning of EtherCAT networks, the following simplified rules can be used:

- The overall length of the communication channel (sum of the lengths of permanent link and patch cords) should not exceed 100 m.
- The overall length of patch cords at each channel end should not exceed 5 meters, and the length of the permanent link should be reduced accordingly (in order to guarantee a maximum total length of 100 m for the channel).
- The maximum number of connections in the channel should be 6 (when counting also the connectors at channel ends) or 4 (when counting intermediate connectors only).
- In any case, the channel length should be kept as short as possible compatibly with the existing environmental constraints

Figure 10 shows different examples of channel architectures:

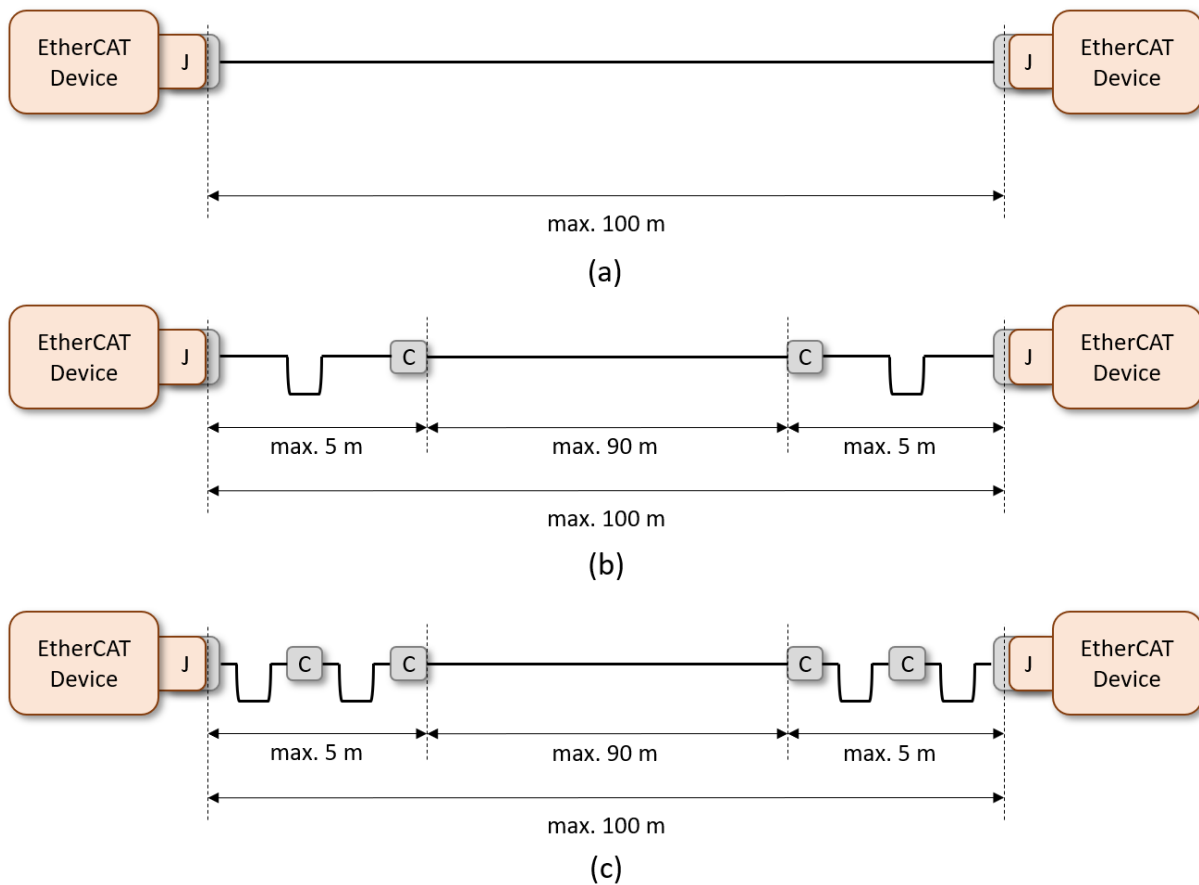

Figure 10: several possible channel architectures

The dimensioning rules reported above refer to a communication channel in non-critical environmental conditions. In case of channel installation in an environment with high EM disturbances, the channel length should be limited accordingly.

According to the ISO/IEC 61784-5-12 profile, in case of 100BASE-TX copper physical medium EtherCAT requires a Class D channel (or higher). The ISO/IEC 11801 specification defines the worst-case corner values for the hardware parameters which guarantee compliance with a Class D channel. A selection of the most relevant among these parameters is described in Table 2.

Table 2: Reference parameters for a Class D channel of 100m length

Parameter	Meaning	Permanent link (@100 MHz)	Channel (@100 MHz)
IL	Insertion Loss, Attenuation	20,4 dB	24 dB
NEXT	Near-end crosstalk	32,3 dB	30,1 dB
ACR	Attenuation-to-crosstalk ratio	11,9 dB	6,1 dB
	Propagation delay	0,491 μ s	0,548 μ s
	Delay skew	0,044 μ s	0,050 μ s

The most relevant channel parameters to be considered during the planning phase are Insertion Loss (IL), Near-end crosstalk (NEXT) and Attenuation-to-crosstalk ratio (ACR).

- The Insertion Loss is a measure, expressed in dB, of the signal attenuation introduced by the communication channel. The larger the absolute value of IL, the greater the signal portion which is lost during the propagation. For example, a value of 20 dB for the IL means that only 10 % of the transmitted differential voltage reaches the receiver. Vice-versa, smaller values for the IL parameter indicate less attenuation and are therefore index of better performances
- The Near-end crosstalk is a measure, expressed in dB, of the influence which the signal transmitted on a twisted pair can have on neighbor pairs. The smaller the absolute value of NEXT, the greater portion of the transmitted signal which appears as induced disturbance on neighbor pairs. For example, a value of 32 dB for the NEXT means that 2,5 % of the differential voltage transmitted on one twisted pair will be received on a neighbor pair and will therefore result in a disturbance. Vice-versa, higher values for the NEXT parameter indicate less crosstalk and are therefore index of better performances.
- The ACR parameter is a measure, expressed in dB, of the channel Signal-to-Noise-Ratio, and is calculated as difference of the (logarithmic) values of IL and NEXT. For example, a value of 6 dB for the ACR means that the attenuated portion of signal received on one twisted pair will be 50% greater than the crosstalk disturbance induced by a signal transmitted with same amplitude on a neighbor pair.

It is important to notice that the values reported in Table 2 refer to the transmission frequency of 100 MHz. As a 100BASE-TX data throughput is transmitted with 4B/5B MLT3 multilevel encoding, the hardware signal will actually have a maximum frequency of 31,25 MHz, and the parameter values at this operating frequency will be about 3-5 times better than those specified at 100 MHz.

The physical meaning of IL and NEXT parameters is described in Figure 11.

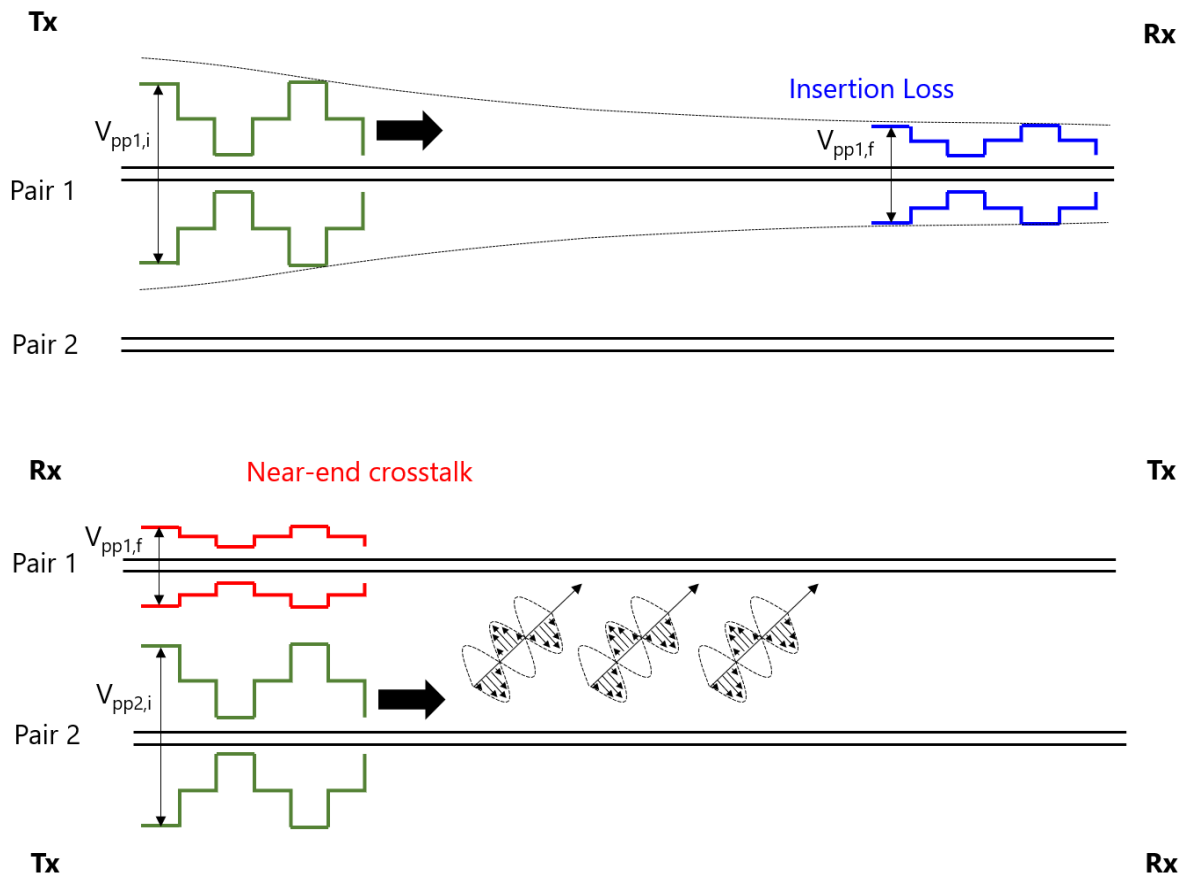

Figure 11: physical meaning of IL and NEXT parameters

Component manufacturers (cables, connectors ...) can certify their products for a specific performance class according to the ISO/IEC 11801 specification. The use of components certified for performance Class D (or higher) is mandatory within EtherCAT networks, but it does not automatically guarantee that the channel will be compliant with the same performance class as well. The compliance of the communication channel with performance Class D should be determined on the basis of the parameter values provided by the manufacturers of all components involved in the channel. In case the parameter values are not known for all the components employed in the connection, the channel compliance to performance Class D (or higher) should be explicitly verified by means of suitable measurements, as described in Subclause 7.2.

Each connection introduces additional attenuation and crosstalk in the channel. The number of intermediate connections should therefore be reduced as much as possible compatibly with the application requirements, and without exceeding in any case the maximum allowed number described in Subclause 5.3.1.

When determining the number of connections, double couplers shall be counted as two separate connections (as shown in Figure 12):

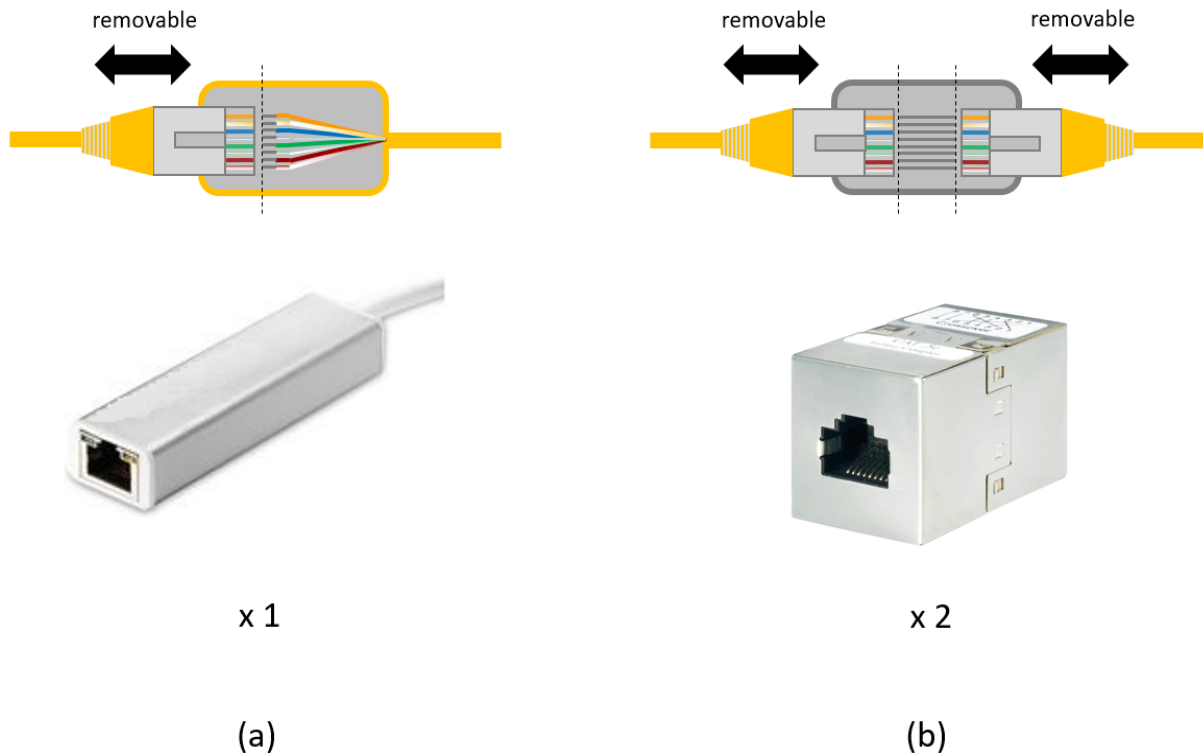

Figure 12: counting the number of connections

Although recommended, the planning of network connections according to the structured cabling model described in the ISO/IEC 11801 specification is not strictly mandatory. Connections which are not based on the rules of structured cabling are defined as application-specific cabling: in this case, channel performances and error-free transmission under all operating conditions should be explicitly verified by means of suitable measurements, as described in Subclause 7.2.

5.3.2 Channel Parameters for 100BASE-FX Link

Table 3: reference parameters for fiber optic channel

Optical fibre type	Description	
Single mode silica	Standard	IEC 60793-2-50; Type B1
	Nominal transmission wavelength λ	1310 nm
	Attenuation coefficient at λ	$\leq 0,5$ dB/km
	Cut off wavelength	< 1260 nm
	Alternative description	
	Mode field diameter (μm)	9...10
	Cladding diameter (μm)	125
	Minimum length (m)	0
	Maximum length (m)	14000
	Multimode silica	Standard
Nominal transmission wavelength λ		1310 nm
Attenuation coefficient at λ		$\leq 1,5$ dB/km
Modal bandwidth at λ		600 MHz x km
Alternative description		
Core diameter (μm)		60 (A1a); 62,5 (A1b)
Cladding diameter (μm)		125
Numerical aperture		0,20 \pm 0,02 or 0,23 \pm 0,02 at 50/125 0,275 \pm 0,02 at 62,5/125
Minimum length (m)		0
Maximum length (m)		2000

Optical fibre type	Description	
POF	Standard	IEC 60793-2-40; Type A4a
	Nominal transmission wavelength λ	650 nm
	Attenuation coefficient at λ	≤ 160 dB/km
	Modal bandwidth at λ	35 MHz x 100m
	Alternative description	
	Core diameter (μm)	980
	Cladding diameter (μm)	1000
	Numerical aperture	$0,5 \pm 0,05$
	Minimum length (m)	0
	Maximum length (m)	50
Plastic clad silica	Standard	IEC 60793-2-30; Type A3c
	Nominal transmission wavelength λ	650 nm
	Attenuation coefficient at λ	≤ 10 dB/km
	Modal bandwidth at λ	70 MHz x km
	Alternative description	
	Core diameter (μm)	200
	Cladding diameter (μm)	230
	Numerical aperture	$0,37 \pm 0,04$
	Minimum length (m)	0
	Maximum length (m)	100

5.4 Cable Selection

The IEC 61784-5-12 profile describes the cable types which are suggested for EtherCAT applications and specifies the worst-case corner values for the cable parameters which should not be exceeded within an EtherCAT channel.

In the planning phase, cable selection should always be done referring to the measured parameters provided by the cable manufacturer.

In case of connections between devices moving with respect to each other, flexible cables should be used in order to prevent cable damage. In this case, parameters like maximum permissible bending radius, as well as maximum tolerated tensile and torsional forces, should be carefully verified to be compliant with the application requirements, as described in Subclause 6.3.

In case of connections installed in chemically aggressive environments, cables with suitable special coating should be used in order to prevent cable damage.

In case of additional environmental constraints in the application, specifically designed cables should be used according to the specific information provided by the cable manufacturer.

5.4.1 Cables for 100BASE-TX Link

For the permanent link, cables should be compliant with the worst-case corner values described in Table 4 and Table 5:

Table 4: reference parameters for fixed cables used for permanent link

Characteristics	Type A cable (fixed)
Nominal impedance of cable (tolerance)	100 Ω \pm 15 Ω (IEC 61156-5)
Balanced or unbalanced	Balanced
DC round-trip resistance ^a	\leq 115 Ω /km
Number of conductors	4 (2 pairs)
Shielding	S/FTQ
Colour code for conductor	WH, YE, BU, OG
Transfer impedance	< 50 m Ω /m at 10 MHz
Installation Type	Stationary, no movement after installation
Outer cable diameter	6,5 mm \pm 0,2 mm
Wire cross section	AWG 22/1
Wire diameter (without insulation)	0,64 mm \pm 0,1 mm
Delay skew	\leq 20 ns/100 m

^a The DC round-trip resistance (also called DC loop resistance) is calculated by measuring the cable DC resistance going both ways, that is connecting the two pair wires on one side of the cable and measuring the resistance between the same wires on the other side. If the resistance is measured between the two cable ends for one single wire, the values obtained will be about the half of those obtained for round-trip resistance, and therefore also the corresponding reference value should be considered \leq 57,5 Ω /km.

Refer to vendor cable specification for additional information.

Table 5: reference parameters for flexible cables used for permanent link

Characteristics	Type B cable (flexible)
Nominal impedance of cable (tolerance)	100 Ω \pm 15 Ω (IEC 61156-5)
Balanced or unbalanced	Balanced
DC round-trip resistance ^a	\leq 115 Ω /km
Number of conductors	4 (2 pairs)
Shielding	S/FTQ
Colour code for conductor	WH, YE, BU, OG
Transfer impedance	< 50 m Ω /m at 10 MHz
Installation Type	Flexible, occasional movement or vibration
Outer cable diameter	6,5 mm \pm 0,2 mm
Wire cross section	AWG 22/7
Wire diameter (without insulation)	0,64 mm \pm 0,1 mm
Delay skew	\leq 20 ns/100 m

a The DC round-trip resistance (also called DC loop resistance) is calculated by measuring the cable DC resistance going both ways, that is connecting the two pair wires on one side of the cable and measuring the resistance between the same wires on the other side. If the resistance is measured between the two cable ends for one single wire, the values obtained will be about the half of those obtained for round-trip resistance, and therefore also the corresponding reference value should be considered \leq 57,5 Ω /km.

Refer to vendor cable specification for additional information.

In fixed cables each wire consists of a massive conductor, while in flexible cables wires consist of several twisted conductors with smaller section (as shown in Figure 13).

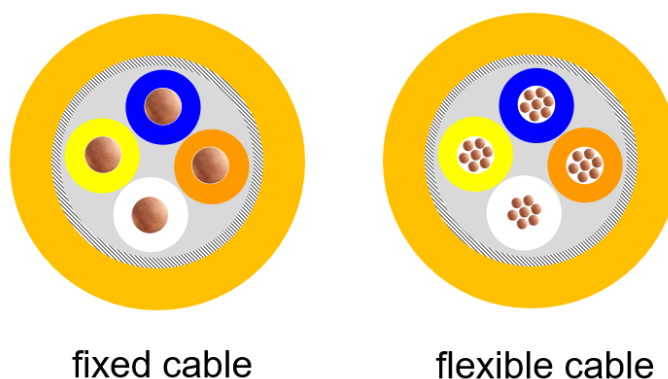

Figure 13: difference between fixed and flexible cables

Parameter values (like for example the Insertion Loss) measured for flexible cables are typically worse than those of fixed solid cables. The use of flexible cables should therefore be limited to scenarios where it is strictly needed, like in case of connections between devices moving with respect to each other. Otherwise, fixed solid cables should be used.

Table 6 reports typical parameter values for a real cable successfully used in EtherCAT applications:

Table 6: example of cable used for permanent link

	Fixed	Flexible
Type	AWG22/1	AWG22/7
Shielding	S/FTQ	S/FTQ
Round-trip resistance	≤ 115 Ω/km	≤ 115 Ω/km
Insertion Loss (@100MHz)	19,5 dB/100m	21,3 dB/100m
Near-end crosstalk (@100MHz)	50 dB/100m	50 dB/100m

Only four wires are used by EtherCAT communication, therefore the use of quad (two-pair) balanced Ethernet cables is recommended.

Four-pair cables can also be used, provided that their performances in terms of IL and NEXT are comparable to those of quad cables and do not exceed the worst-case corner values reported in Table 4 and Table 5: the presence of additional unused pairs - especially if these are not properly terminated in the two end devices - could in fact increase signal crosstalk between neighbor pairs and therefore reduce the cable performances.

Indication for device manufacturers

EtherCAT device manufacturers are encouraged to terminate unused pairs with $75\ \Omega$ resistors, which should be connected to the virtual ground, as shown in Figure 14.

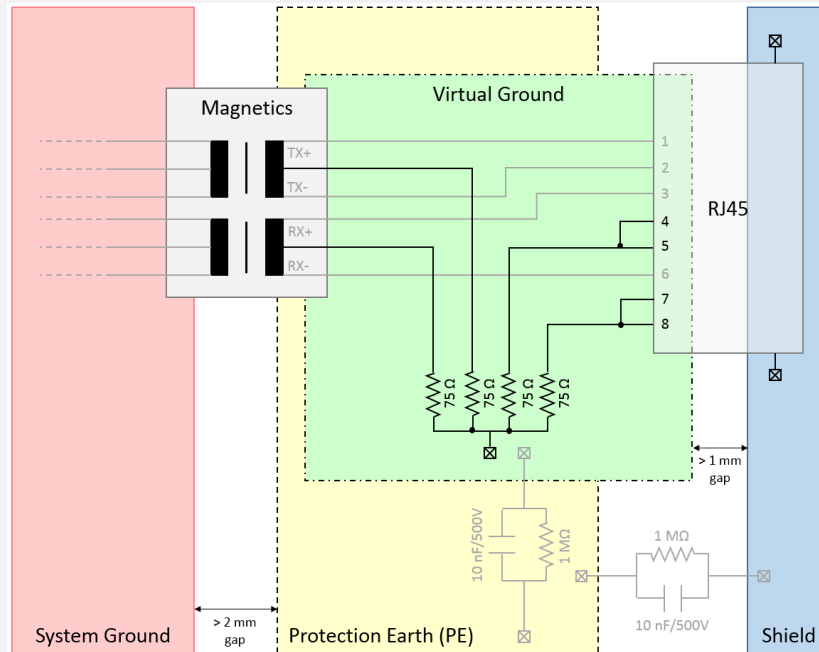

Figure 14: proper termination of unused pairs within a device

In case of four-pair cables, the recommended connector pin assignment is the one defined as T568B in the TIA-568-C specification at both cable ends, which implies a straight cable structure. Nevertheless, all slave hardware interfaces mandatorily support auto-crossover capability, therefore straight cables with pin assignment corresponding to T568A at both cable ends, as well as cross cables, can also be used within EtherCAT networks.

An exception concerning this aspect is represented by slaves supporting the Fast Hot-Connect technology. In this case – in order to reduce the time required for the connection establishment – the hardware interface parameters like transmission rate, duplex mode and straight/cross connection are preset and will not be negotiated (IN-ports use MDI-setting, the OUT-ports MDI-X). For this reason, the use of straight cables in conjunction with the Fast Hot-Connect technology is mandatory.

The ISO/IEC 11801 specification defines a standardized coding for the shielding scheme of Ethernet copper cables:

xx/yTQ TQ = Twisted Quad (two-pairs)
 or
xx/yTP TP = Twisted Pair (four-pairs)

Where:

xx = external cable shielding

- U = unshielded
- F = foil shielding
- S = stranded shielding
- SF = stranded + foil shielding

y = additional cable shielding (for quad cables) / pair shielding (for twisted pair cables)

- U = unshielded
- F = foil shielding
- S = stranded shielding

Table 7 reports some shield coding examples:

Table 7: examples of cable shield coding

ISO/IEC 11801 code	Type	Cable shielding	Additional/pair shielding
U/UTQ	twisted quad	none	none
U/UTP	twisted pair	none	none
S/UTQ	twisted quad	stranded	none
S/UTP	twisted pair	stranded	none
SF/UTP	twisted pair	stranded + foil	none
S/FTQ	twisted quad	stranded	foil
U/FTP	twisted pair	none	foil
S/FTP	twisted pair	stranded	foil
SF/FTP	twisted pair	stranded + foil	foil

EtherCAT recommends the use of at least externally shielded cables, both for the permanent link and for patch cords (as shown in Figure 15).

The stranded solution should be preferred for the external cable shielding, as it provides higher mechanical robustness. When using externally foil-shielded cables, particular care should be paid not to damage or to interrupt the shield itself.

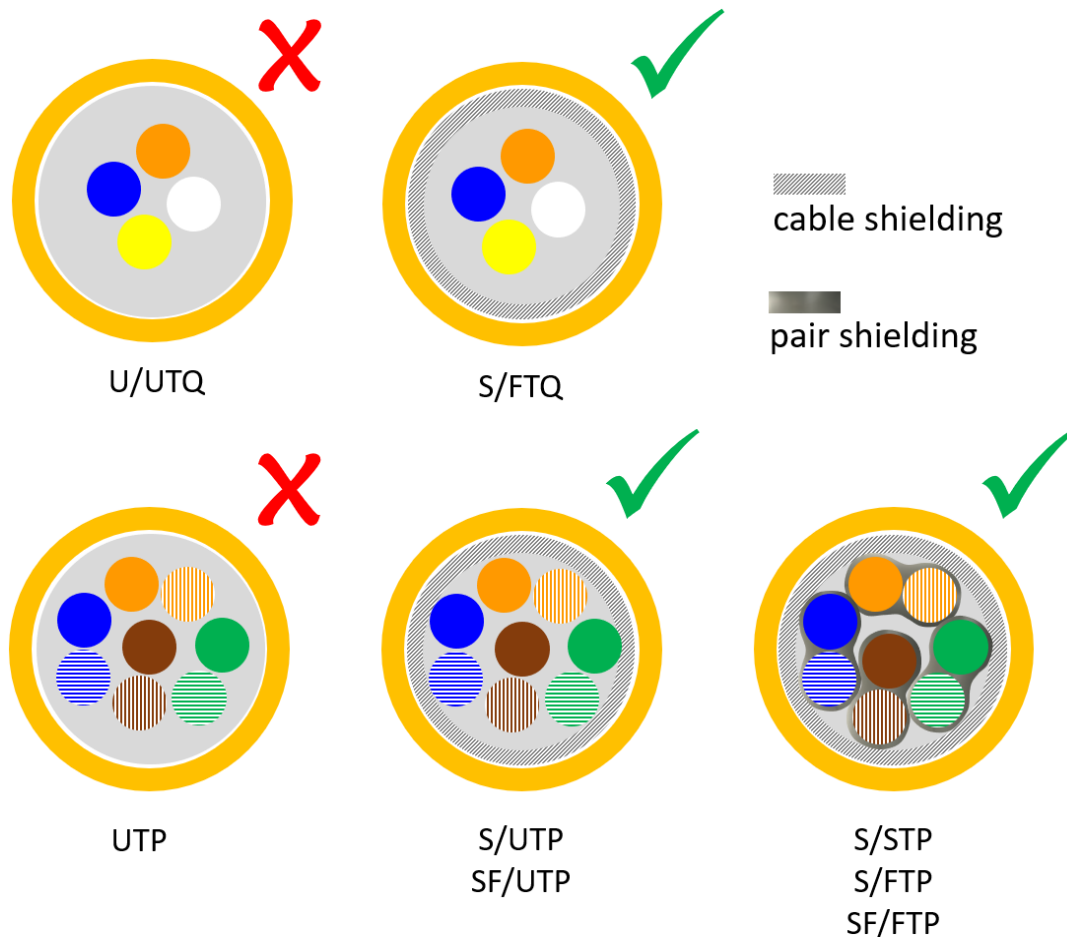

Figure 15: recommended and discouraged shielding configurations

Concerning cable diameter, the American Wire Gauge (AWG) standard defines the following coding rule:

AWGx/y

Where:

x = AWG category (increasing with decreasing conductor diameter)

y = number of wires forming the conductor

Error! Reference source not found. reports some AWG coding examples.

Table 8: correspondence between conductor diameter and AWG coding

AWG coding	Wire structure
AWG 20	
AWG20/1	massive
AWG20/7	7x0.320 mm
AWG20/10	10x0.254 mm
AWG 22	
AWG22/1	massive
AWG22/7	7x0.254 mm
AWG22/19	19x0.160 mm
AWG 24	
AWG24/1	massive
AWG24/7	7x0.203 mm
AWG24/10	10x0.160 mm
AWG26	
AWG26/1	Massive
AWG26/7	7x0.160 mm
AWG26/10	10x0.127 mm

The smaller the AWG coding number, the larger the diameter of the conductors, and therefore the smaller the signal attenuation for a given cable length.

For the permanent link, it is highly recommended to use cables with diameter AWG22 or larger (i.e. described by smaller AWG coding numbers). Cables with smaller diameter values (like AWG24 or AWG26) should not be used for long connections outside cabinets.

For short connections within cabinets, patch cables with smaller diameters like AWG24 or AWG26 can also be used. Cables with such smaller diameters are characterized by higher resistance values and higher signal attenuation. In the planning phase, hardware parameters for cables with conductor diameter smaller than AWG22, either provided by cable manufacturers or directly measured as described in Subclause 7.2, should be carefully evaluated, as they could limit the overall channel length to distances significantly shorter than 100 m due to the higher attenuation value.

5.4.2 Cables for 100BASE-FX Link

Table 9: reference parameters for fiber optic cables

Characteristics	9..10/125 μm single mode silica	50/125 μm multimode silica	62,5/125 μm multimode silica	980/1000 μm step index POF	200/230 μm step index hard clad silica
Attenuation per km (650 nm)	-	-	-	≤ 160 dB/km	≤ 10 dB/km
Attenuation per km (820 nm)	-	-	-	-	-
Attenuation per km (1300 nm)	$\leq 0,5$ dB/km	$\leq 1,5$ dB/km	$\leq 1,5$ dB/km	-	-
Number of optical fibres	2	2	2	2	2
Connector type (duplex or simplex)					
Jacket colour requirements	-				
Jacket materials	-				
Resistance to harsh environment (e.g. UV, oil resist, LSOH)	Application dependent				
Breakout	Yes	Yes	Yes	Yes	Yes

5.5 Connector Selection

The IEC 61784-5-12 profile defines the standard connector types specified for EtherCAT applications (reported in Table 10 and Table 11). The connector types specified for EtherCAT in the IEC 61784-5-12 are further specified in the following documents:

- IEC 60603-7-3, for RJ45 shielded connectors (copper cables)
- IEC 61076-2-101, IEC 61076-2-109 and IEC 61076-3-117 for M12 connectors (copper cables)
- IEC 61076-2-104 for M8 shielded connectors (copper cables)
- IEC 61076-2-114 for M8 connectors with P-Coding (copper cables, only for EtherCAT P)
- IEC 61754-4, for SC connectors (optical fibers)
- IEC 61754-24, for SC-RJ connectors (optical fibers)

In the planning phase, the connector selection should always be performed referring to the measured constructive parameters provided by the connector manufacturer.

The connector selection should take the specific mechanical constrains of the application into account, in order to prevent permanent damage of cables and connectors themselves.

In case of links installed in chemically aggressive environments, suitable special connectors should be used in order to prevent damage of the cable and of the connector itself.

Table 10: standard connectors for copper cables

IEC 60603-7-3^a	RJ45 (shielded)	^a For IEC 60603-7-x, the connector section is based on channel performance. ^b rectangular protective housing with push-pull coupling. ^c Only applicable in conjunction with EtherCAT P.
IEC 61076-3-117^b	RJ45 (shielded)	
IEC 61076-2-101	M12-4 with D-coding	
IEC 61076-2-109	M12-8 with X-coding	
IEC 61076-2-104	M8-4 with A-coding (shielded)	
IEC 61076-2-114^c	M8-4 with P-coding	

Table 11: standard connectors for fiber optic cables

IEC 61754-4	SC	IEC 61754 series defines the optical fibre connector mechanical interfaces; performance specifications for optical fibre connectors terminated to specific fibre types are standardized in the IEC 61753 series.
IEC 61754-24	SC-RJ	

When using connector types not specified in the IEC 61784-5-12, the compliance to performance Class D (or higher) must be ensured under all operating conditions by means of electrical measurements, such as those described in Subclause 7.2.3.

In addition, device manufacturers shall provide together with the device suitable adapters from the non-standard connector format to one of those specified in the IEC 61784-5-12. The use of adapters is not allowed in case of EtherCAT P interfaces.

5.6 Cable Separation

In order to prevent EM disturbances to corrupt the signals and therefore affect the communication performances, the network planning should always guarantee a suitable separation of communication cables from other cable types, and especially from power cables like supply lines or motor connections (as described in Figure 16).

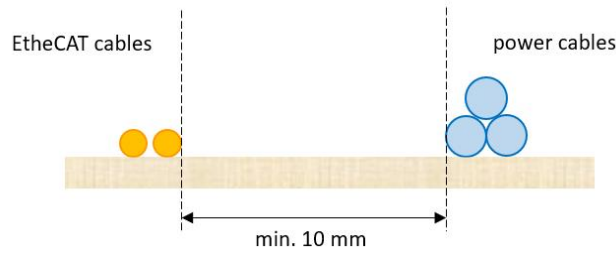

Figure 16: minimum distance between communication and power cables

In order to improve the immunity to EM disturbances and to reduce the minimum permissible distance from power lines, EtherCAT cables can be routed through metallic enclosures or conduits as shown in Figure 17.

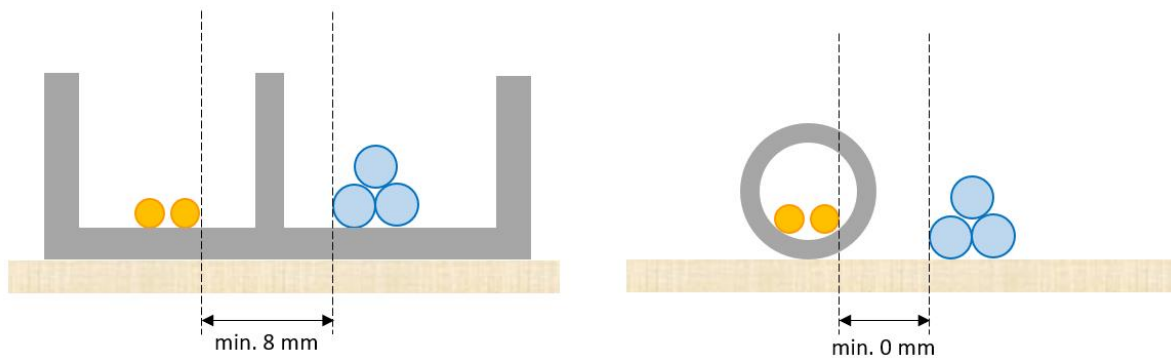

Figure 17: minimum distance with metallic separation conduits

Suggested copper cables with parameter values reported in Subclause 5.4.1 comply with Separation Class D described in Table 3 of [13]. Table 12 reports the minimum distances which should be observed between EtherCAT shielded cables and power cables for several possible metallic separation types according to Table 3 of [13].

Table 12: reference values for minimum distance between communication and power cables

Type of separation	Minimum distance ^{a, b}
Without metallic separation	10 mm
Open metallic cable conduit	8 mm
Perforated metal plate conduit	5 mm
Bulky cable conduit	0 mm

a minimum distance values are valid for overall current values within the power cables up to 300 A and 230 V. For higher current values a derating factor shall be taken into account, according to Table 5 of [13].

b in case of copper cables not complying with the parameter values suggested in Subclause 5.3.1, higher separation distances may apply according to Table 3 of [13].

5.7 Earthing and Grounding

In order to provide the highest immunity against EM disturbances as well as undesired noise, all the electronic components and chassis enclosures or metallic pathways within the machine or plant should be kept at the same reference potential by means of suitable earthing connections.

According to the ISO/IEC 61918 specification, two earthing schemes have proven to be effective in the industrial environment: equipotential and star.

5.7.1 Equipotential Earthing

In the equipotential earthing, devices chassis and pathways are connected wherever possible to the building metallic structure, which is in turn connected to the functional earth (Figure 18). This forms a mesh providing the same reference potential to all EtherCAT devices and infrastructure components.

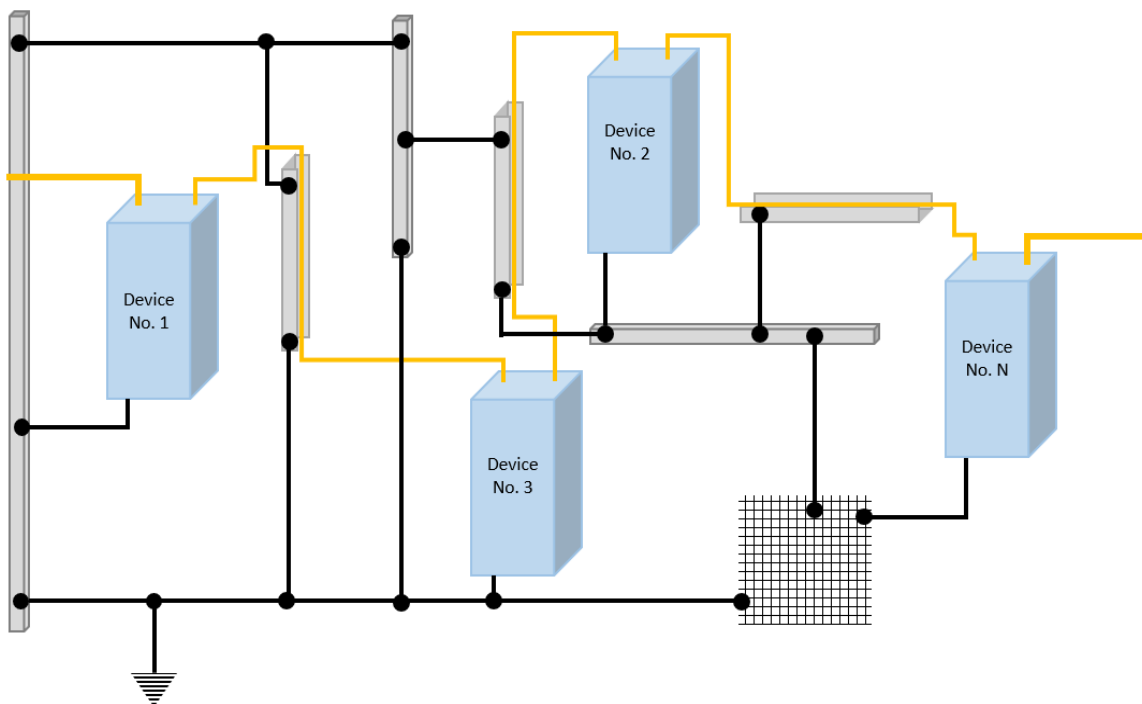

Figure 18: equipotential earthing scheme

5.7.2 Star Earthing

In case medium or high currents are generated within the application, earth paths would form current loops which could in turn determine potential differences among network devices. In this case, a star connection to a single point which is in turn connected to the functional earth could represent a more effective earthing solution (Figure 19).

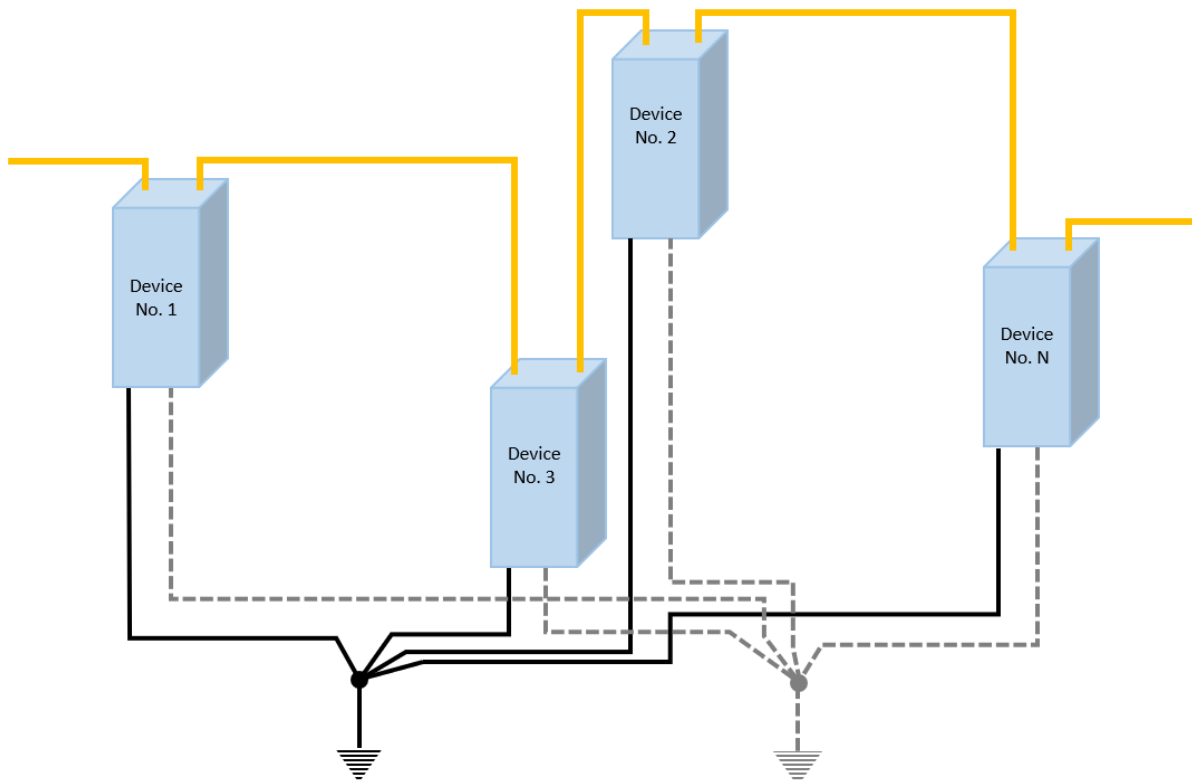

Figure 19: star earthing scheme

The connection of device chassis and metallic pathways to earth should be performed through specifically dedicated wires with the appropriate coloring scheme according to the different national standards. In order for the earthing system to provide efficient rejection of EM disturbances and undesired noise, the impedance between each device or metal chassis and the functional earth should be as low as possible, typically lower than $0,6 \Omega$ and in any case lower than 1Ω .

As the overall resistance of a wire is proportional to its length, earthing wires should always be kept as short as possible.

The overall resistance of a wire is also proportional to its cross-section. Table 13 shows the relationship between the cross-sectional area of an earthing wire and its maximum length which will ensure a resistance of $0,6 \Omega$, suitable to provide an adequate earthing effect.

Table 13: relation between cross section and length of earthing wires

Cross-sectional areas		Maximum length ^a
IEC 602228	AWG	(a)
	8,36 (8 AWG)	291 m
10 mm ²		349 m
	10,5 (7 AWG)	368 m
	13,3 (6 AWG)	461 m
16 mm ²		556 m
	16,8 (5 AWG)	582 m
	21,1 (4 AWG)	736 m
25 mm ²		870 m

a Length of a conductor having a resistance $R = 0,6 \Omega$

The maximum lengths reported in Table 13 should be considered as best-case values, as devices typically show an impedance between the local earth and the RJ45 connector, and the RJ45 connector may have an own impedance as well. Depending on the environmental conditions, the earthing should be improved or additional external earth to shield connections may be necessary, as described in Subclause 7.2.

5.8 Selection of Infrastructural Components

The use of infrastructural components different from cables, like slip rings, optical data couplers or others, and not integrating an EtherCAT Slave Controller (see Clause 4), should be carefully evaluated as it could impact on the network performances, cause frame loss and even prevent the EtherCAT functional principle described in Subclause 5.4 from working.

As described in Clause 4.4, ESCs support routing capabilities, and they can implement all possible topologies. External routing components like switches are therefore not needed to implement star or tree topology architectures, and they can only degrade the network performances in terms of propagation delays, communication jitter and proper routing order of EtherCAT frames. The use of switches within EtherCAT networks is therefore highly discouraged and should be avoided.

Infrastructural components should be certified for performance Class D (or higher) under all operating conditions, as well as against ageing. Each end-to-end link including infrastructural components should be tested by means of suitable measurements as described in Subclause 7.2, and the EtherCAT-specific diagnostic information described in Subclause 7.4 should always be evaluated during the commissioning phase in order to verify that no frames are lost, and that the signals are not corrupted or excessively attenuated due to the infrastructural components themselves.

Some infrastructural components, like some slip rings or media converters or others are active devices, that is they regenerate the EtherCAT signal. When such components are inserted between two EtherCAT devices, the connection between the upstream and the downstream device is split into two different channels, with independent physical link detection and establishment, which are not terminated by an ESC at each end. If the physical link between the infrastructural component and the downstream device is interrupted, the link between the upstream device and the infrastructural component could remain active: in this case, the upstream slave will keep its port open causing loss of frames (Figure

20), as the infrastructural component does not internally support the capability to close the EtherCAT logical loop.

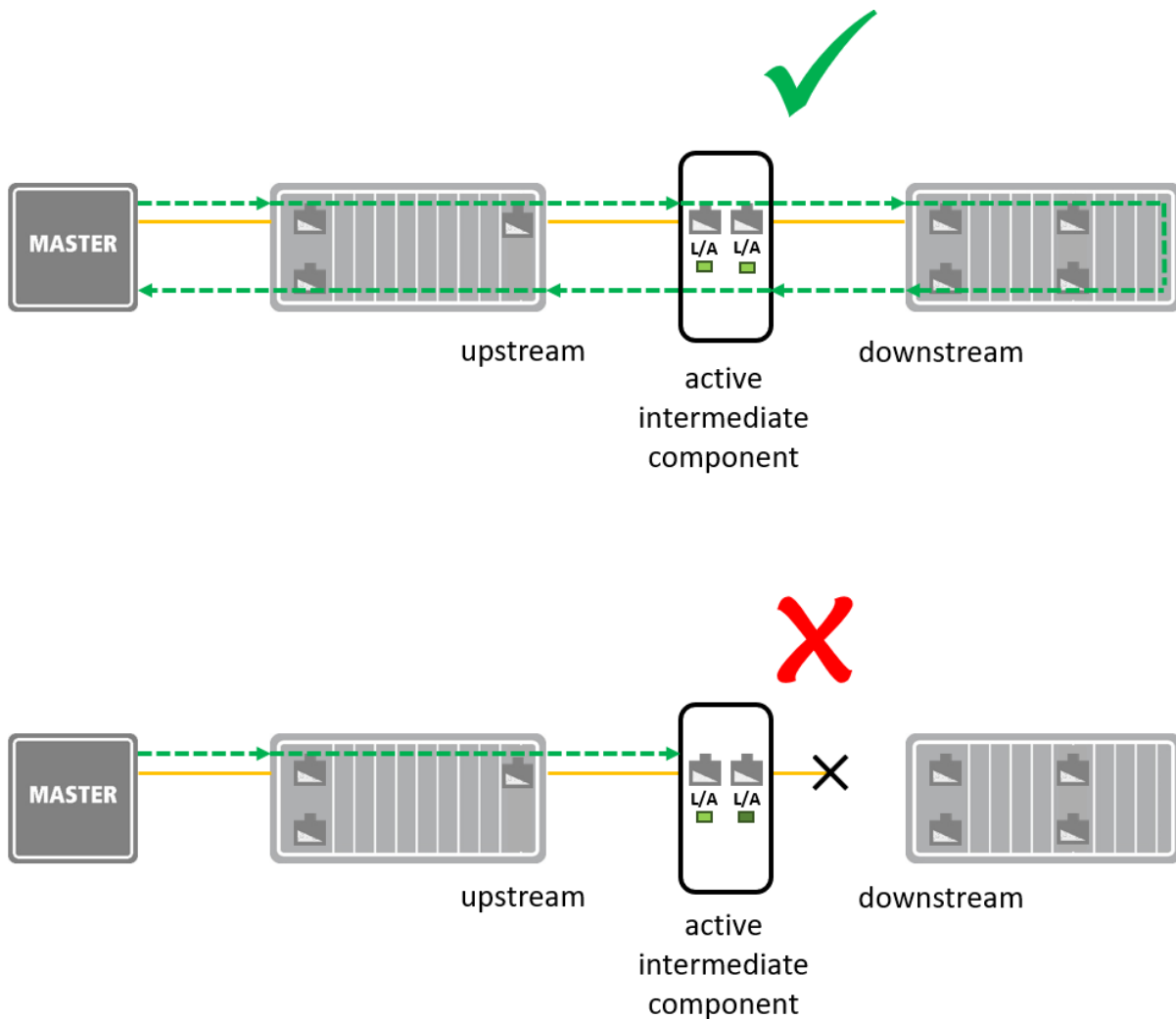

Figure 20: behavior in case of active infrastructure component

Active infrastructural components used in EtherCAT networks should therefore support mechanisms ensuring that, if the hardware connection between the intermediate component and the downstream slave is interrupted, the intermediate component will close the link with the upstream slave as well, forcing in turn the upstream slave to close its port and the EtherCAT logical loop with it, thereby preventing from frame loss. This behavior for active infrastructural components can be obtained, for example, by means of dedicated mechanisms like Link Lost Forwarding (LLF) or others.

In order to provide a reliable link management, as well as advanced diagnostic capabilities, manufacturers of infrastructural active components which are intended to be used in EtherCAT networks are encouraged to integrate an ESC in their devices. The ESC should be located immediately after the upstream PHY, and would always ensure the preservation of the EtherCAT logical loop in case of link interruption, as well as the prevention of frame losses.

Indication for device manufacturers

The correct link management for active infrastructural components described above can be obtained, for example, through the implementation of mechanisms like Link Lost Forwarding (LLF) or similar.

Another possible solution, which would provide more extensive diagnostic information in addition to a correct management of the physical links in case of interruption of the downstream connection, would be to integrate an EtherCAT Slave Controller within the active infrastructural component (Figure 21).

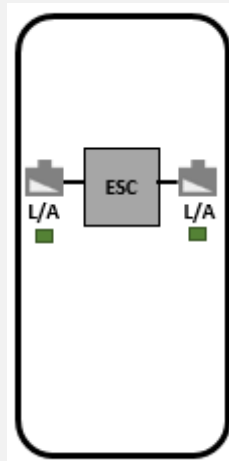

Figure 21: integration of ESC within active infrastructural components

5.9 Selection of EtherCAT Slave Devices

The product spectrum of EtherCAT devices is very wide, therefore end users can select the components which best fit their requirement within a large variety of available devices. The ETG website provides a Product Guide (<https://www.ethercat.org/en/products.html>), which offers an overview of technical characteristics for several products available on the market, as well as links to more detailed information provided by the device manufacturer. It should in any case be remarked that the list of devices reported in the ETG website is not exhaustive, nor it represents a quality criterion for the components.

All EtherCAT slave manufacturers are mandatorily required to test their devices with the official Conformance Test Tool, in order to guarantee the compliance with the main aspects of the EtherCAT specification as well as the interoperability with other devices.

In addition, EtherCAT devices can be tested and certified by external EtherCAT Test Centers. This test is highly encouraged to ensure an even higher degree of compatibility and interoperability.

The mounting and commissioning of EtherCAT devices should always be performed according to the information provided by device manufacturers.

5.10 Additional Tasks in the Planning Phase

Scope of the planning phase should also be to reduce the overall operational costs of a machine or caused by maintenance or unexpected failures. Minimizing the installation and material costs should not

be the primary goal when planning the cabling infrastructure, as communication is the backbone of an automation system.

The present guideline describes reasonable measures which can be adopted during the planning phase with limited additional costs, yet which can produce significant advantages in terms of money and time saving in the life cycle of the machine or plant.

Some of the aspects are more critical than other ones and thus, a good knowledge of the conditions around the automation system is very helpful. Table 14 reports some of the additional tasks which could be included into the planning phase.

Table 14: possible additional tasks in the planning phase

Recommendation	Comment
Define a reliability level for the cabling and/or determine a total cabling cost target.	The awareness increases if there is an economic goal for keeping the cost of cabling really low.
Evaluate critical paths	Most of the cabling has no problems but some areas can cause problems. The main focus should be on cabling hot spots.
High quality cables and connectors recommended	Replacement of cables is expensive.
Try to keep environmental temperature of components low.	The increase of temperature has negative effects for electronics but also some impact on data transmission.
Plan a cable inspection.	A visual inspection can identify problems, and some resistance measurement can help to identify problems
Ensure short repair time in case of errors	The repair time is an important element of availability and requires spare parts and well trained maintenance staff
Documentation of network structure	Documentation (including length, cable types) helps to identify errors during operation.

6 Assembling

6.1 General Procedures for Assembling

The basic information concerning cable routing of Clause 5 applies. Refer to Subclauses 5.6 “Cable separation” and 5.7 “Earthing and Grounding”.

The assembly should be done by experienced technicians and they should follow the cabling plan.

6.2 Electromagnetic Protection

As described in Subclause 5.6, communication cables should be always laid with a minimum separation from other cable types and especially from power cables.

In case communication cables must cross power lines, this should always take place at a 90° angle, as shown in Figure 22.

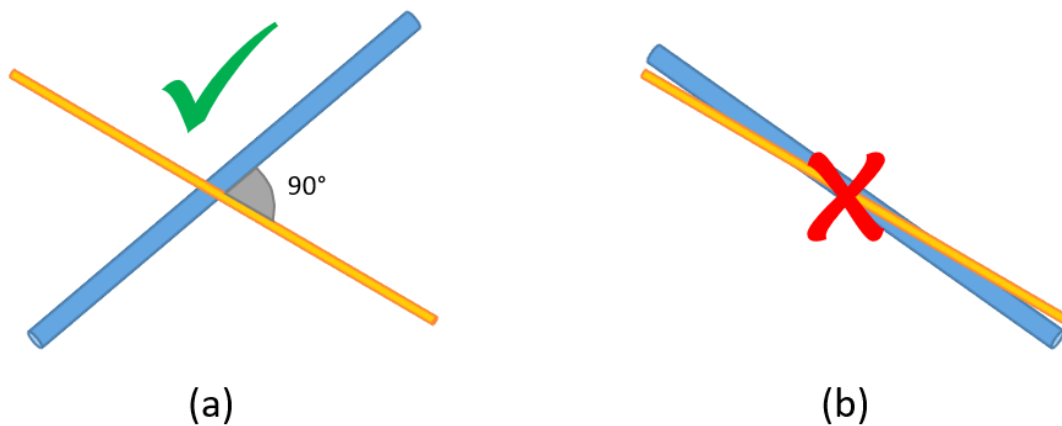

Figure 22: crossing between communication and power cables

Coils in the communication cables should be avoided, as they represent large areas where EM disturbances can be introduced into the network and severely affect the communication performances (Figure 23).

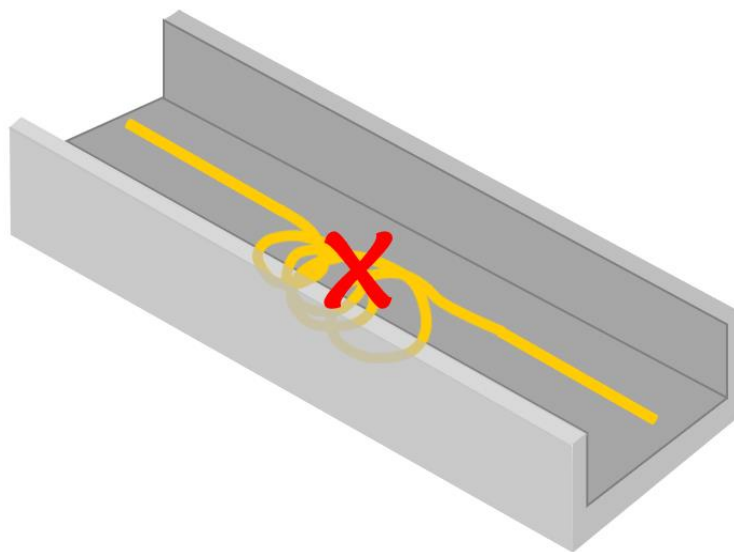

Figure 23: avoiding loops in communication cables

As only shielded cables should be used within EtherCAT networks, particular care should be paid to the earthing of cable shields, in order to minimize noise and disturbances within the communication system.

The cable shield should be connected to earth at both channel ends, and the two end devices should be always at the same reference potential as described in Subclause 5.7.

Indication for device manufacturers

Slave manufacturers are encouraged to properly connect the cable shield to earth within their devices (Figure 24). A RC connection is suggested (Figure 25). In case this is not possible, a direct connection should be provided.

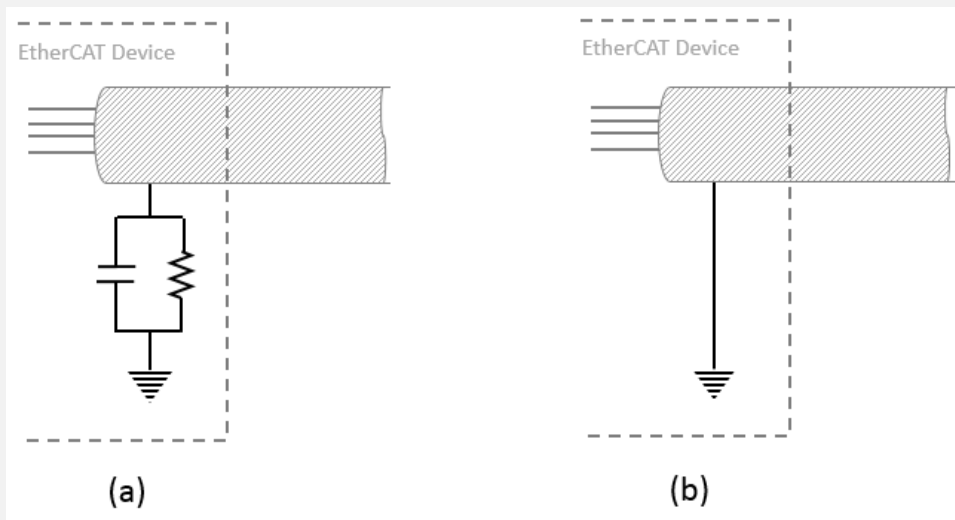

Figure 24: shield-to-earth connection options within a device

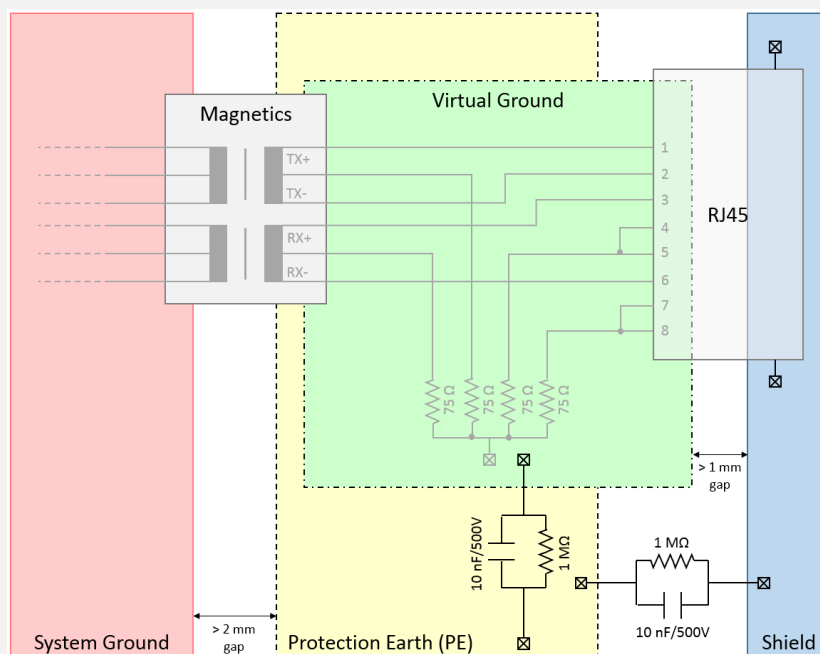

Figure 25: internal RC connection to earth within devices

As a connection between the cable shield and the local earth is typically provided internally by EtherCAT slave devices, an additional external connection of the shield to earth at cable end is generally not required. Please refer to the mounting instructions of slave devices for specific indications concerning the external shield connection to earth.

The specific earthing method used in each slave device can be checked after installation by measuring the impedance value between the metallic part of the connector and the local earth (as shown in Figure 26).

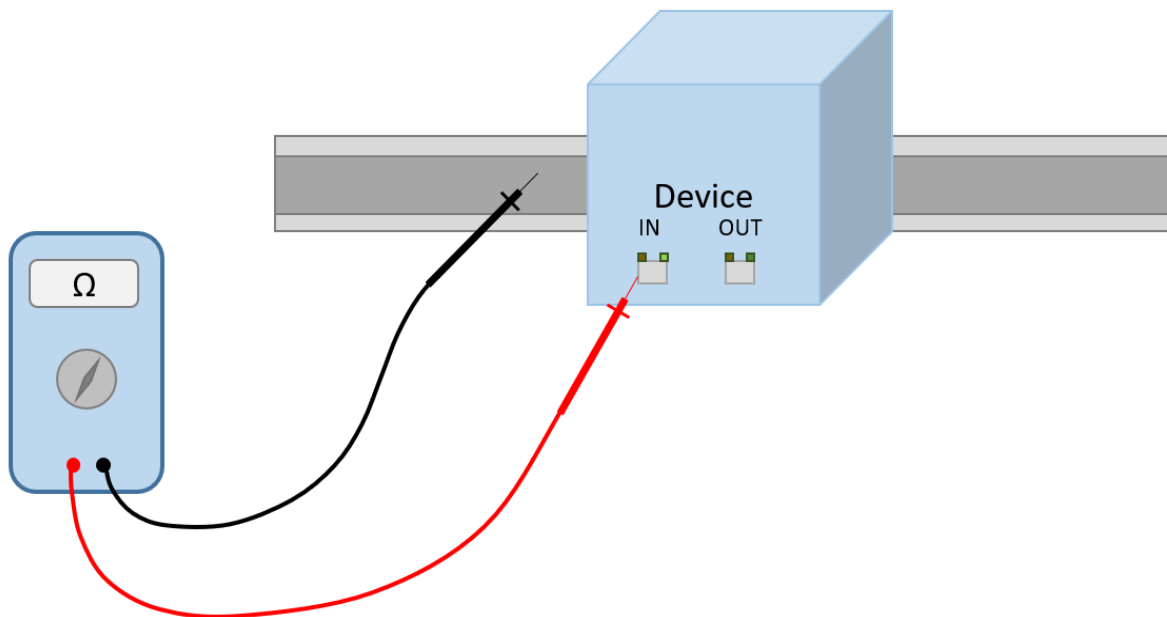

Figure 26: measurement of shield earthing within devices

The result of this measurement can be one of the following:

- Very high impedance values (in the order of magnitude of M Ω). In this case, the cable shield is most probably earthed within the device via an RC connection.
- Very low impedance values (lower than 1 Ω). In this case, the cable shield is most probably earthed within the device via direct connection.
- Open circuit. In this case, the cable shield is most probably not earthed within the device at all.

In case of direct internal connection of the cable shield to earth with relatively high impedance values (1 Ω or greater), if the cable shield is not internally connected to the local earth at all, or in any case if the diagnostic information collected during the commissioning phase (as described in Subclause 7.4) detects hardware communication errors, an external connection of the cable shield to the local earth

could be added in order to improve immunity to noise and equalizing currents by using specifically intended cable clips (as shown in Figure 27):

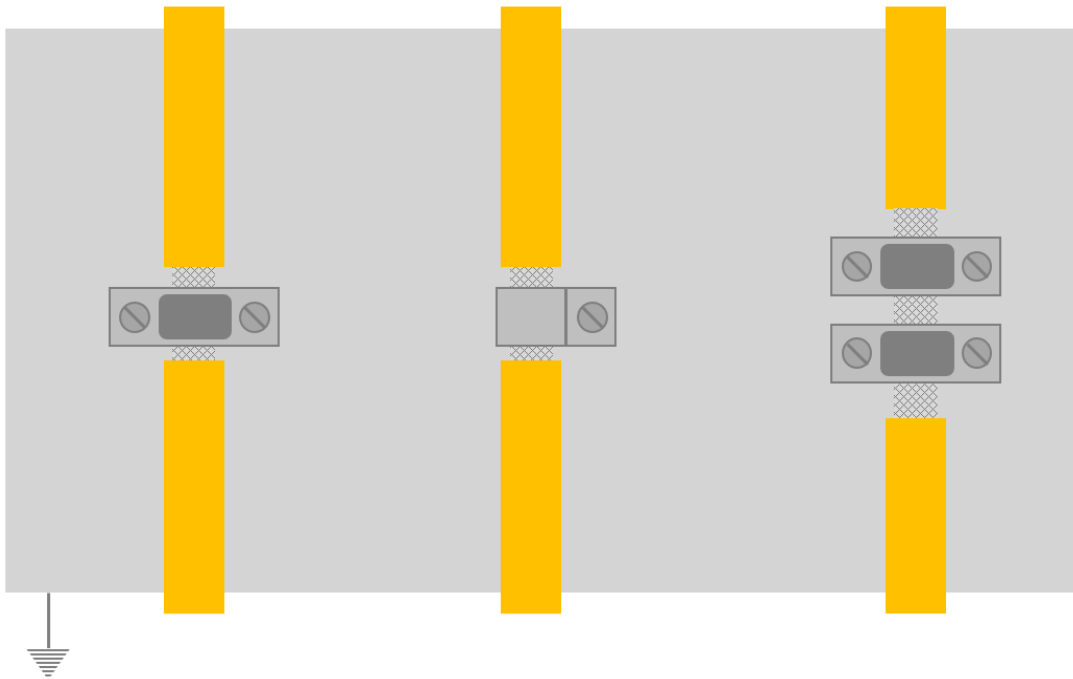

Figure 27: external earthing of the cable shield via cable clips

When using cable clips, the following rules should be observed:

- a) The path to earth should guarantee a very low impedance (0.1Ω or smaller).
- b) The cable clips should exactly fit with the cable diameter: if too tight, cable clips could mechanically damage the cable; if too loose, they could introduce additional noise into the system (Figure 28).

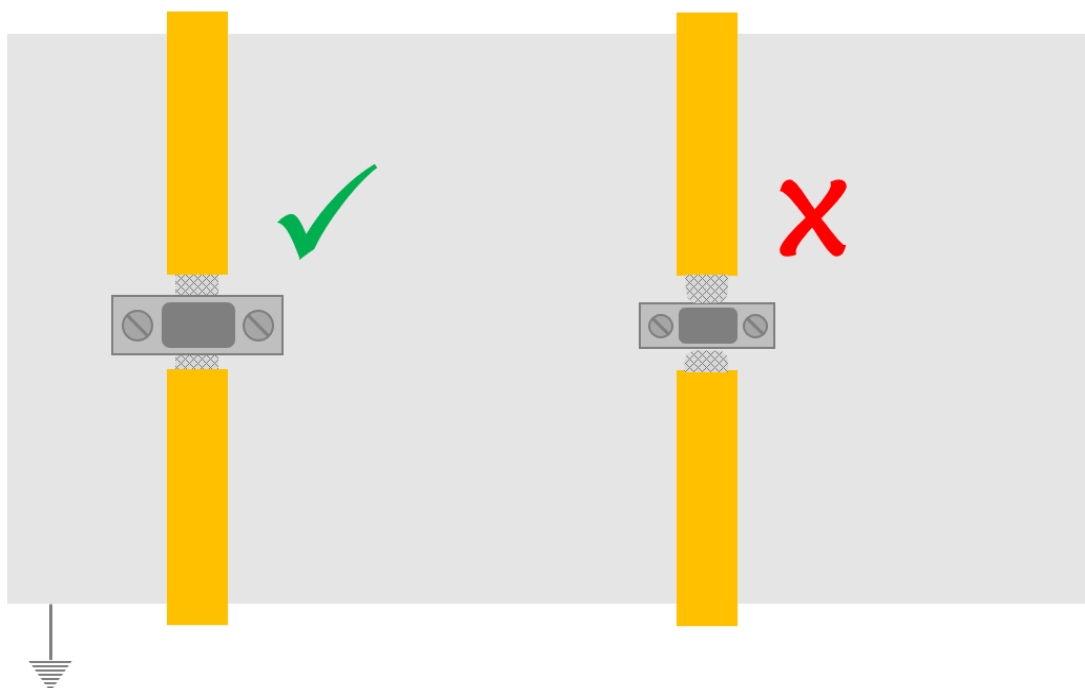

Figure 28: proper and improper size of cable clips

- c) The cable shall not be damaged or interrupted when stripping the outer cable jacket, otherwise the EM barrier provided by the shield would be interrupted (Figure 29).

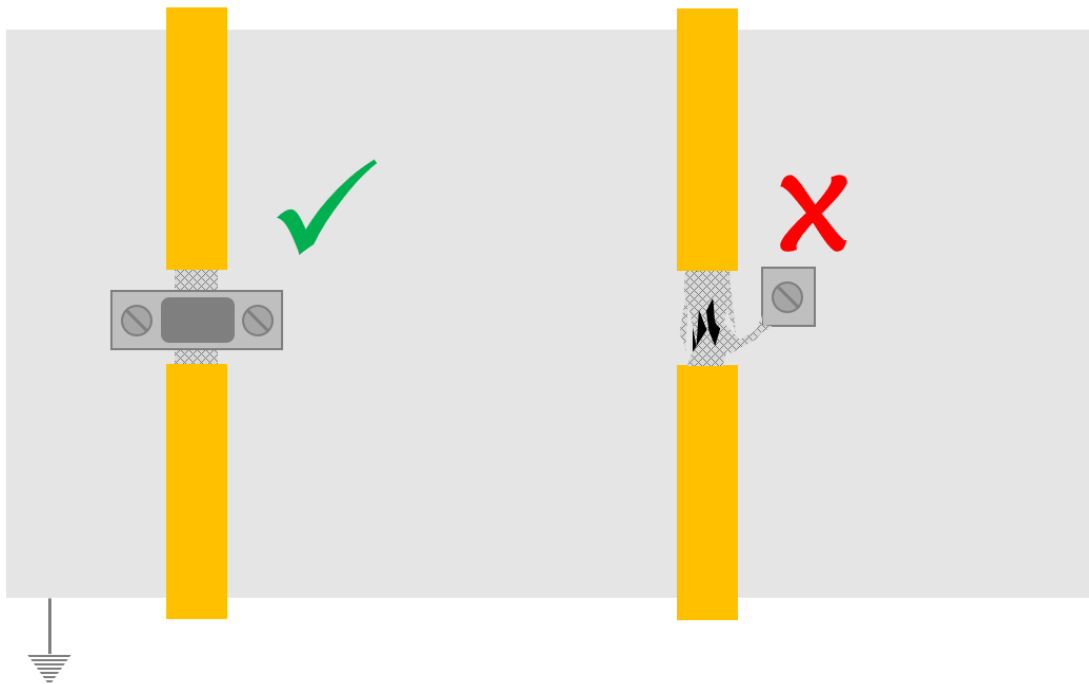

Figure 29: proper and improper shield handling at earthing point

- d) Cable clips for shield earthing connection should not be used for strain relief. Dedicated strain relief components should be used for this purpose, as described in Subclause 6.3.

As an alternative to cable clips, perforated metal plate foils directly providing a low impedance path (0.1Ω or smaller) between the metallic connector of the communication cable to the local earth could be used, as shown in Figure 30.

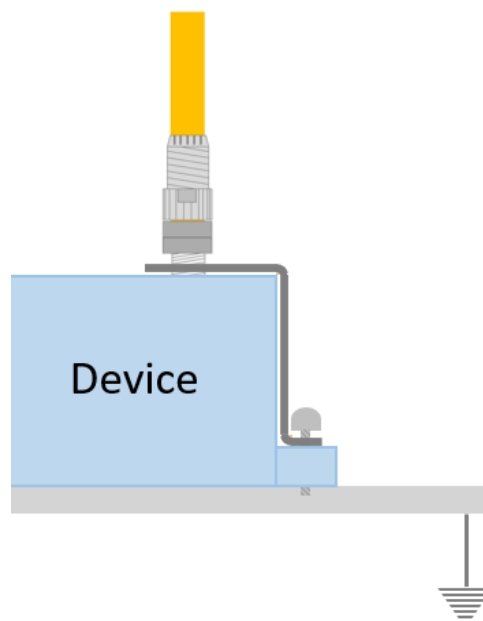

Figure 30: external earthing of the cable shield via metal foils

In case bulkhead feed-through connectors are used to provide access to a cabinet, these should also have the lowest possible impedance path (0.1Ω or smaller) to earth. In order to obtain this, a suitably large contact area between the metallic parts of feed-through connectors and cabinet should be provided, in case removing part of the cabinet painted coating.

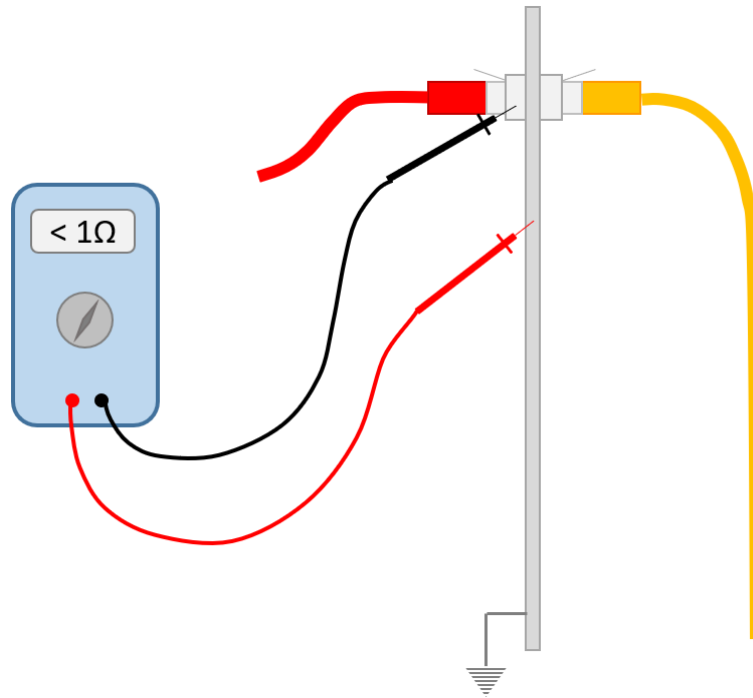

Figure 31: proper earthing of bulkhead feed-through connectors

6.3 Mechanical Protection

Communication cables cannot be arbitrarily bent. Excessive bending could permanently damage the cable wires and the protecting shield, seriously affecting the communication performances. During installation, the minimum bending radius declared by the specific cable manufacturer should always be observed. As a rule of thumb, for a fixed backbone cable a minimum bending radius of 8÷10 times the cable diameter should be guaranteed (as described in the TIA-568-C specification).

In order to prevent the communication cables from excessive bending, specific mechanical aids can be used (as shown in Figure 32):

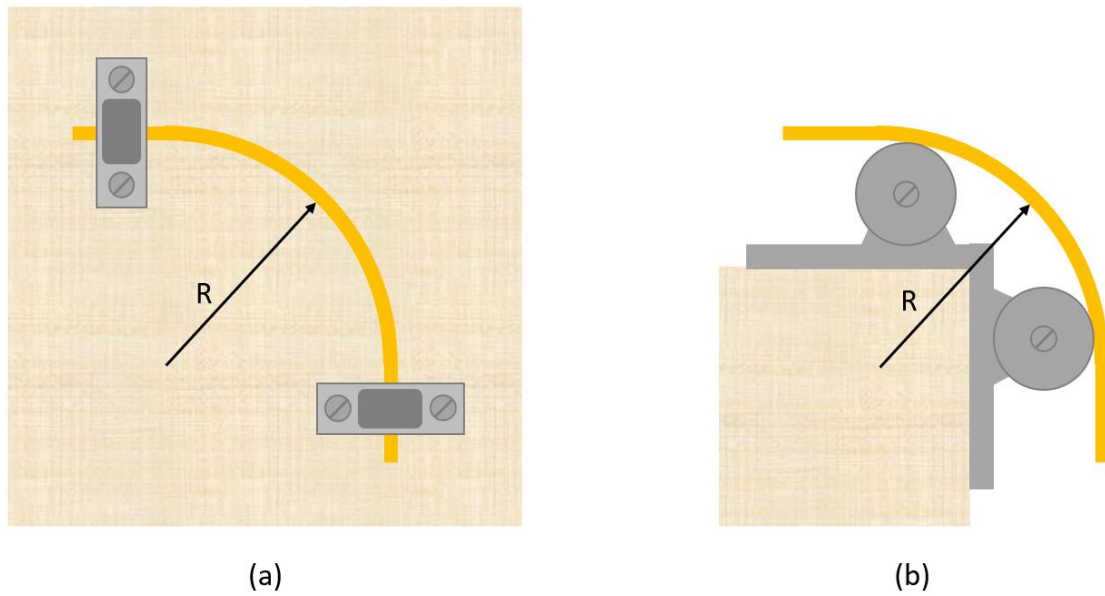

Figure 32: maintaining the minimum bending radius of communication cables

Sharp edges can be particularly dangerous for the cable integrity, especially in case of parts moving with respect to each other. Therefore, sharp edges should be smoothed or provided with specific protections (as shown in Figure 33), in order to prevent cables from being damaged.

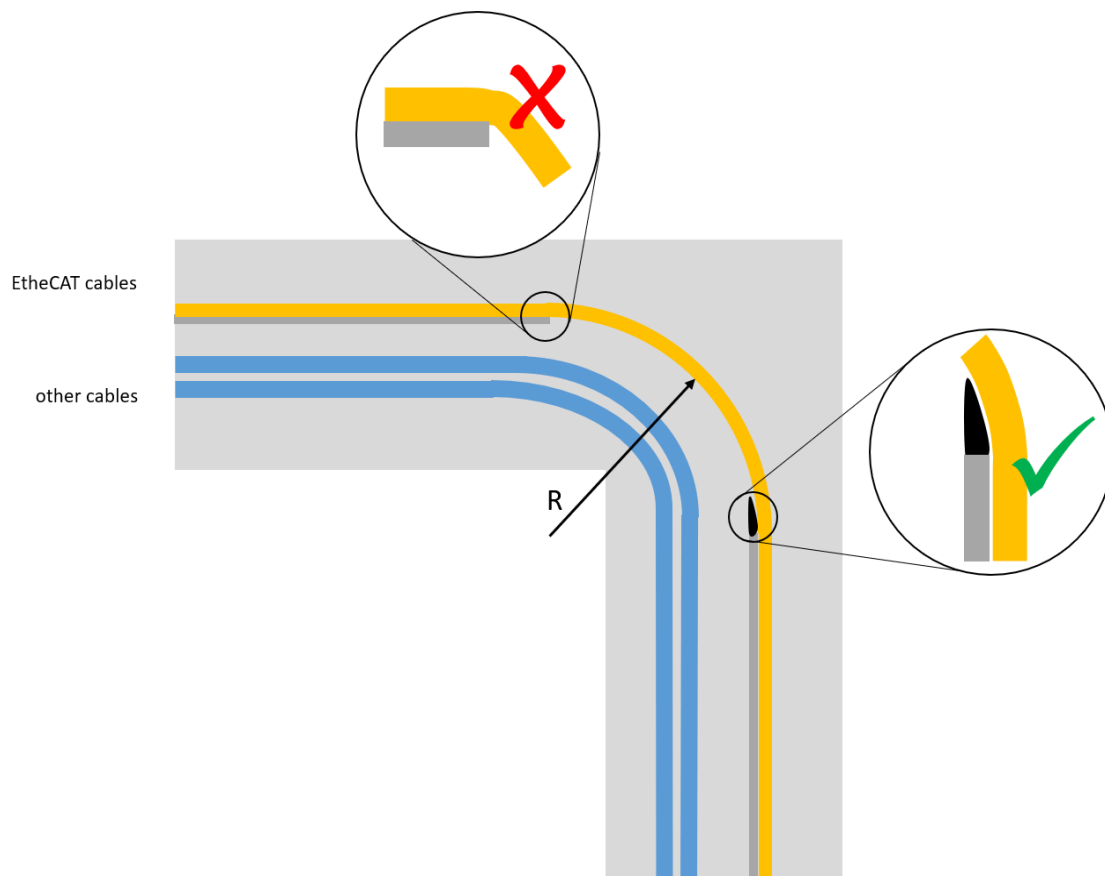

Figure 33: protection of sharp edges along the path of communication cables

Tensile forces (described in Figure 34) could also represent a risk for the cable integrity. During installation, it should always be guaranteed that the tensile forces suffered by communication cables never exceed the maximum allowed value specified by the cable manufacturer. As a rule of thumb, for a fixed backbone cable a maximum tensile force of 110 N should not be exceeded (as described in the TIA-568-C specification).

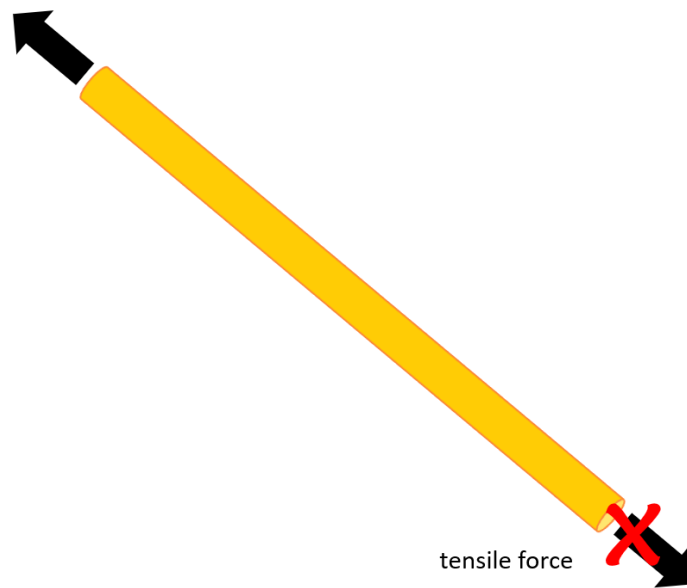

Figure 34: tensile forces acting on communication cables

In case tensile forces could exceed the maximum allowed value specified by the cable manufacturer in some or all operating conditions, strain relief aids should be used (as shown in Figure 35). Strain relief clips should be placed at a suitable distance from the nearest cable connector which prevents the cable from exceeding its maximum bending radius (according to the information provided by the cable manufacturer).

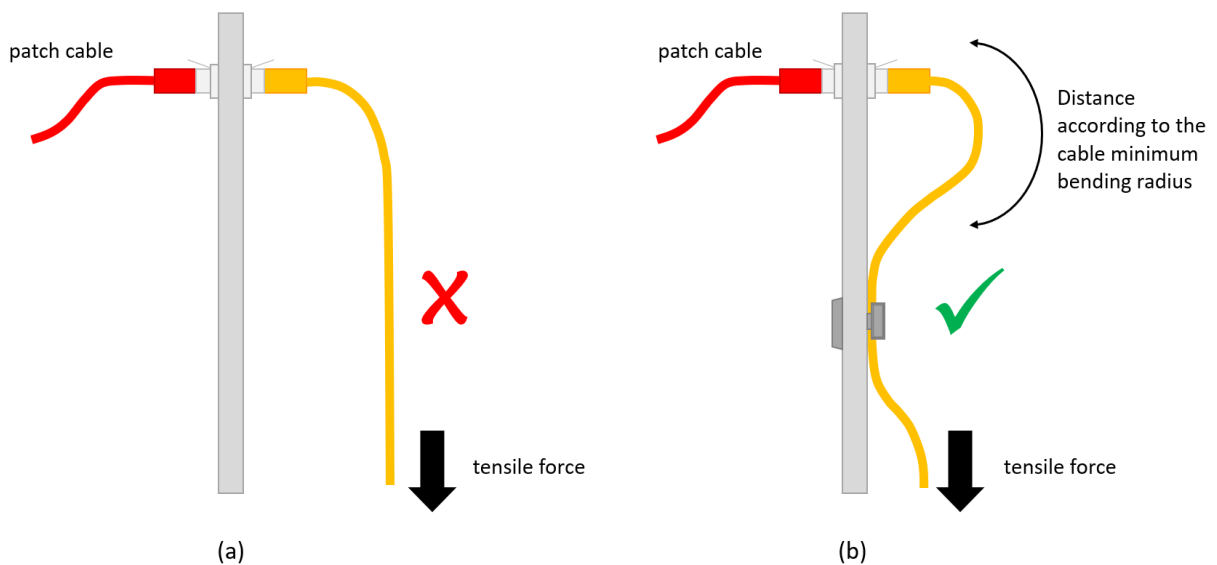

Figure 35: protecting communication cables against tensile forces

Strain relief clips should exactly fit with the cable diameter, in order to prevent permanent cable damage (Figure 36).

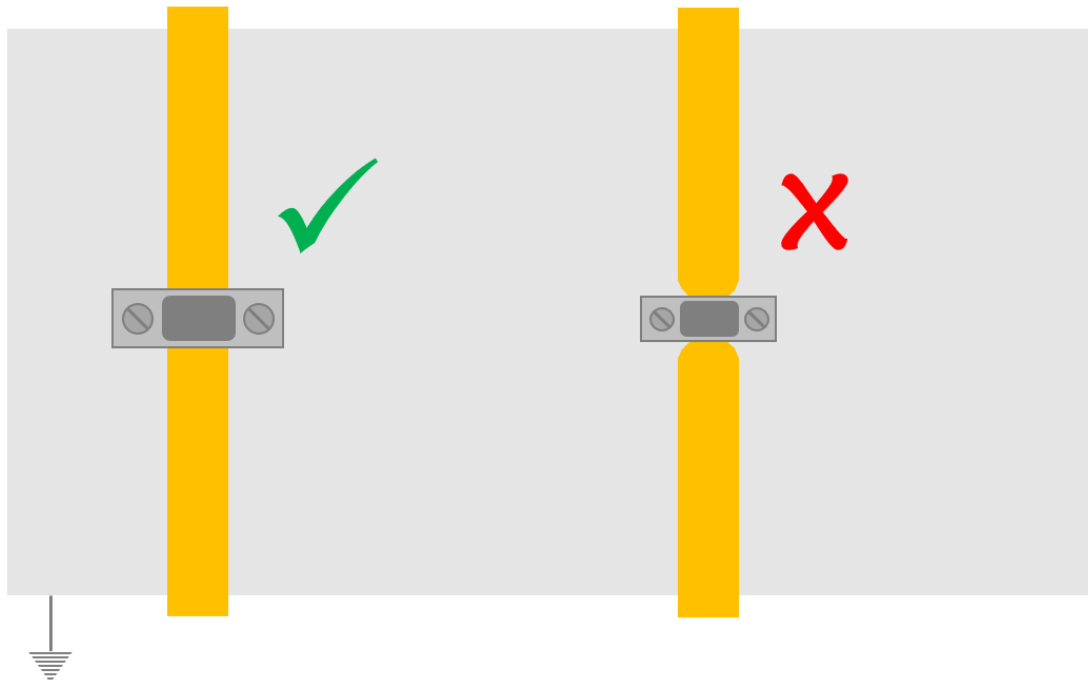

Figure 36: proper and improper dimensioning of strain relief components

Torsional forces (described in Figure 37) could cause a shift of the pair wires with respect to each other reducing the twisting effect, or even permanently damage the cable. Therefore, torsional forces should be avoided whenever possible.

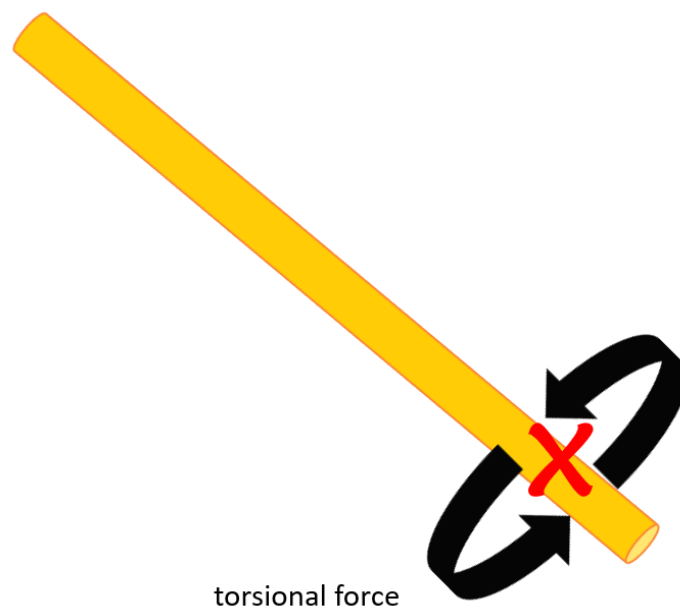

Figure 37: torsional forces acting on communication cables

In case the application includes parts moving with respect to each other and torsional forces cannot therefore be avoided, only flexible cables specifically designed for constant movement should be used, according to the information provided by the cable manufacturer.

Cable crushing should be avoided. In case communication cables could potentially be crushed by mechanical moving parts or cabinet doors, adequate mechanical protection should be provided (as shown in Figure 38).

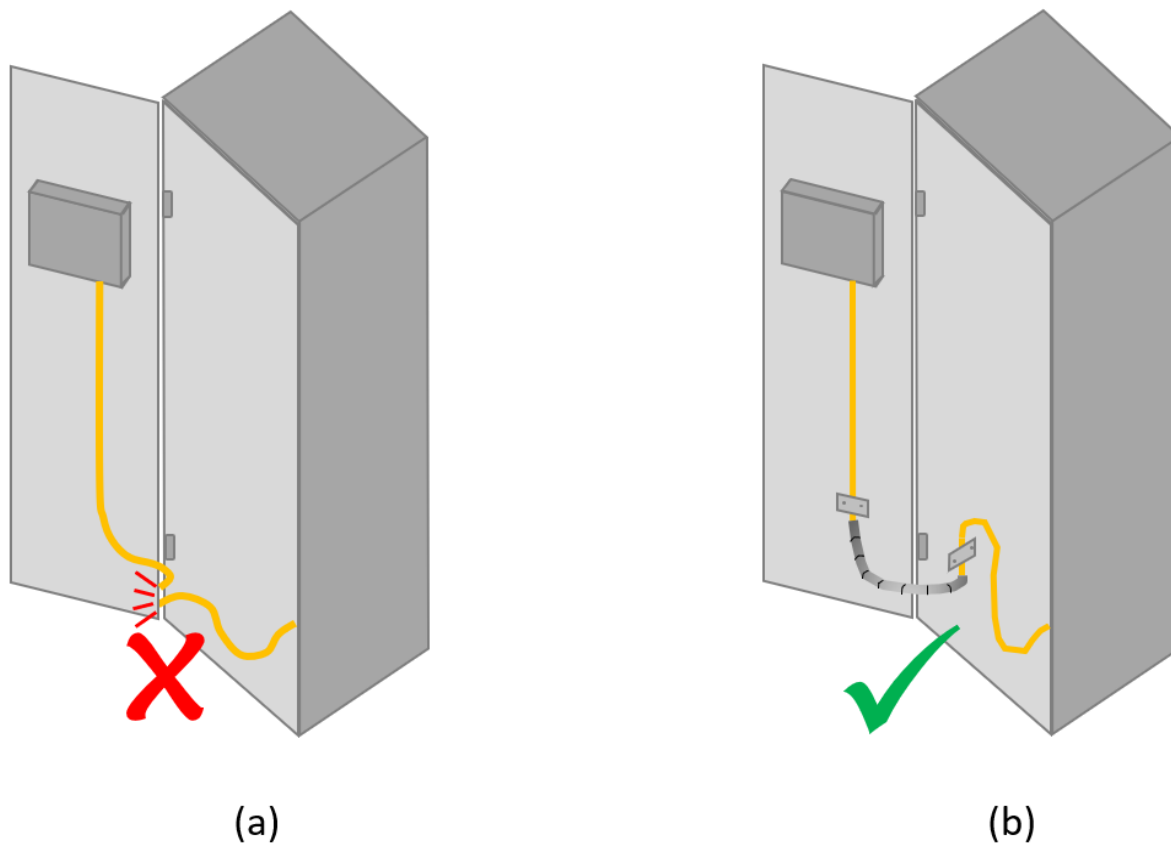

Figure 38: protect communication cables against crushing

6.4 Connector Assembling

The ISO/IEC 61918 standard defines wire color standard and connector pin assignment for quad cables, as shown in Figure 39.

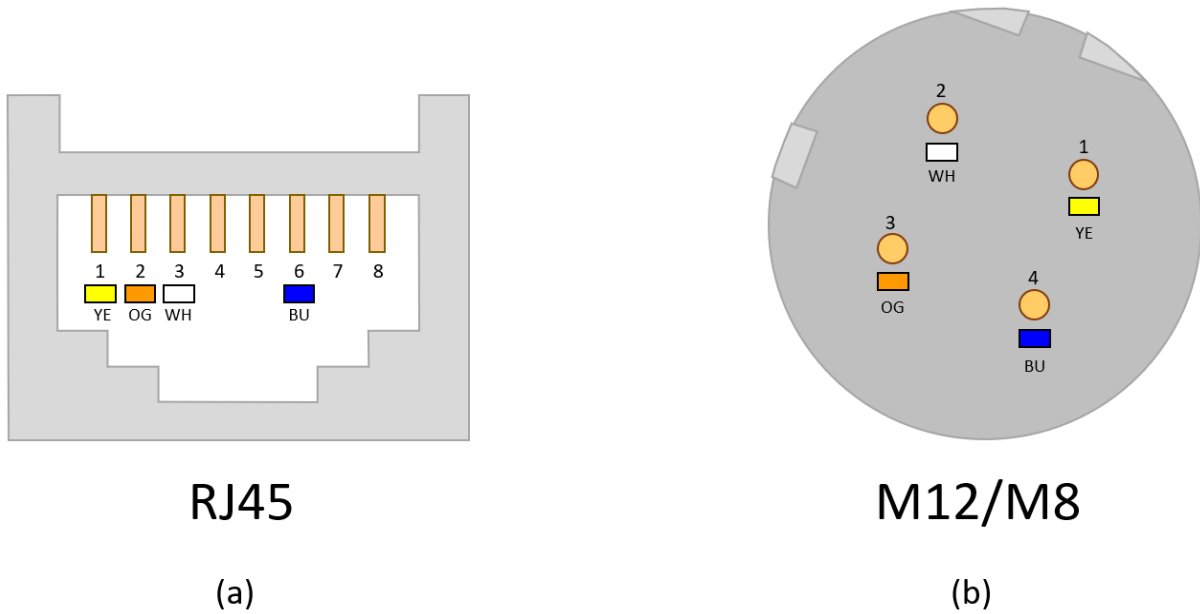

Figure 39: connector pinout assignment for quad cables, according to ISO/IEC 61918

Particular care should be provided when employing field-assembled cables. The connector assembly should be performed with the help of specifically intended tools, preserving the wire and shield integrity. Annex I of the ISO/IEC 61918 specification provides general tips for the connector assembly in case of Ethernet copper cables.

6.4.1 Assembly of RJ45 Connectors

In case of RJ45 connectors, the following steps should be followed:

- a) Strip back the cable jacket for the length specified by the connector manufacturer in the corresponding mounting instructions:

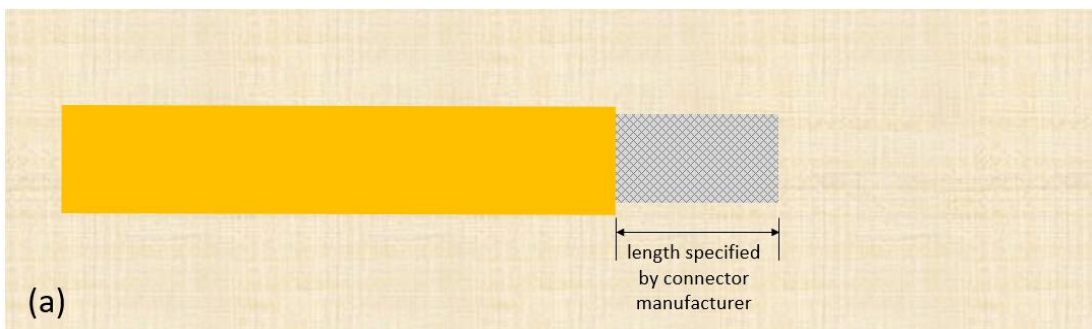

- b) Fold the shield back to the end of the cable jacket, separate the wire pairs and align them as shown. During this process, take particular care to keep the pairs twisted almost down to their end and not to damage the shield itself. Then, trim off the length in excess for the length specified by the connector manufacturer in the corresponding mounting instructions:

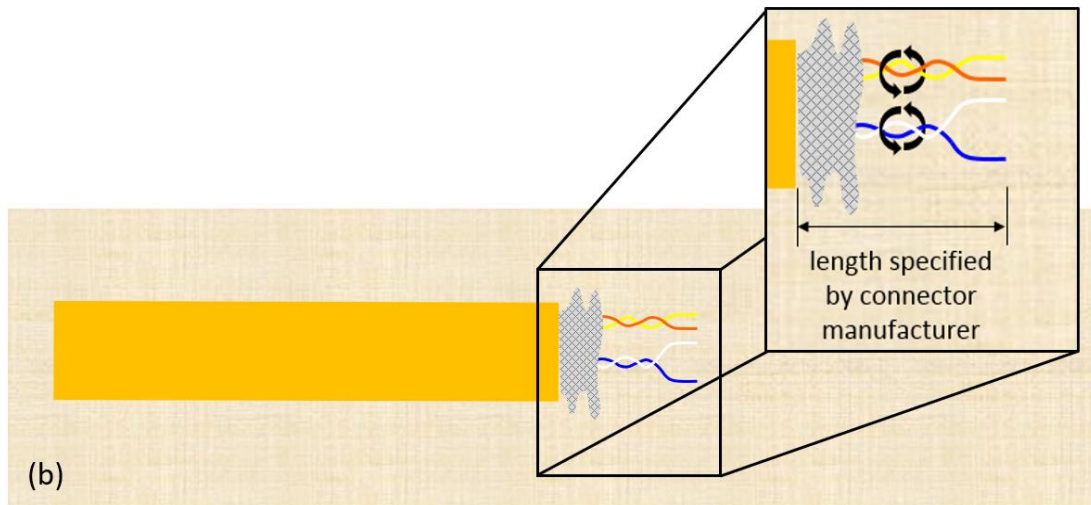

- c) Check the correct wire orientation according to the required pinout assignment. In order to make this step easier, several connectors provide splice elements or other mechanical aids which keep the single wires steady and in the correct position for the following crimping process. Please refer to the mounting instructions of the specific connector for further details.
- d) Insert the conductors into the connector body. In this process, ensure that all wires touch the end of the connector body:

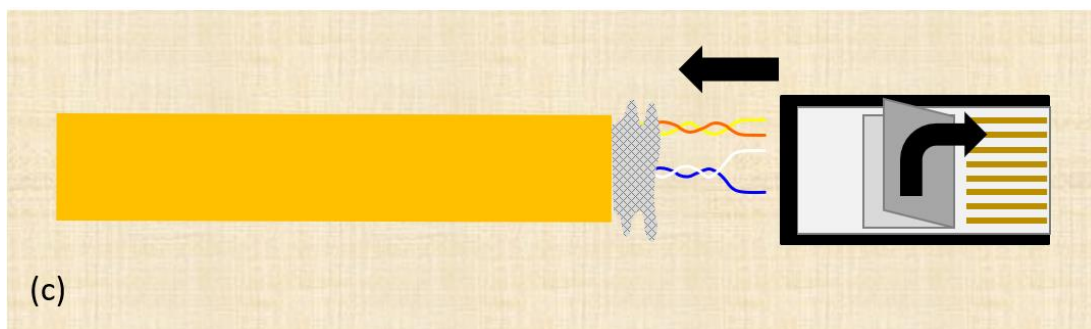

- e) Close/crimp the connector, then check it by gently pulling it:

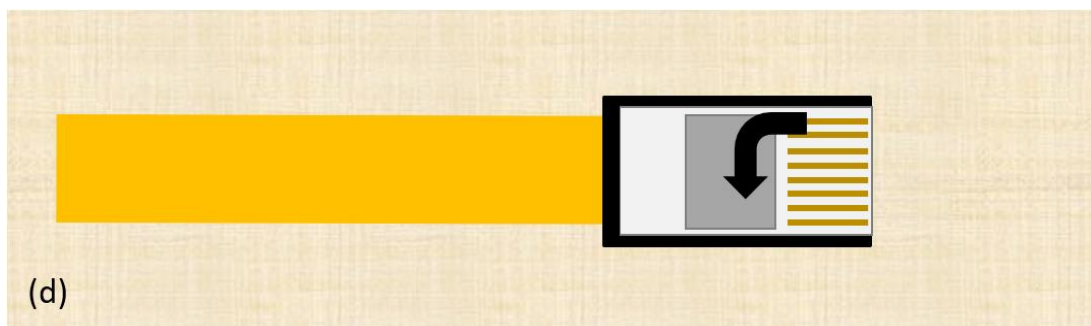

- f) Finally, check the pin-to-pin continuity of each wire between cable ends with a multimeter.

6.4.2 Assembly of M12 and M8 Connectors

In case of M12 and M8 connectors, the following steps should be followed:

- a) Slide the wire gland, nut and connector shell on the cable:

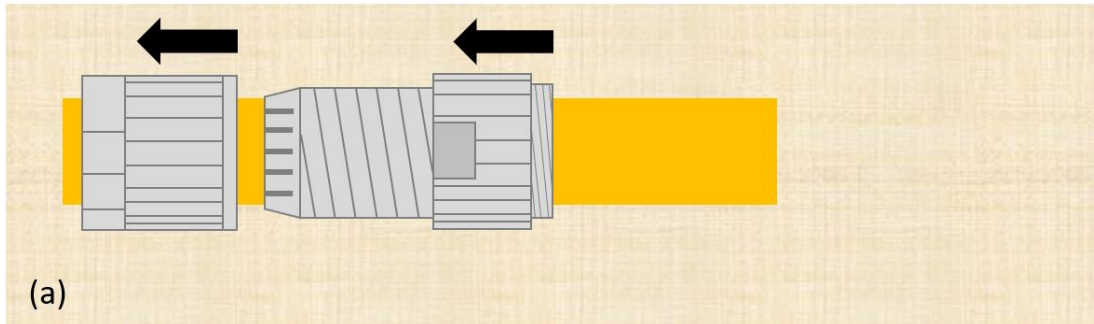

- b) Strip back the cable jacket for the length specified by the connector manufacturer in the corresponding mounting instructions:

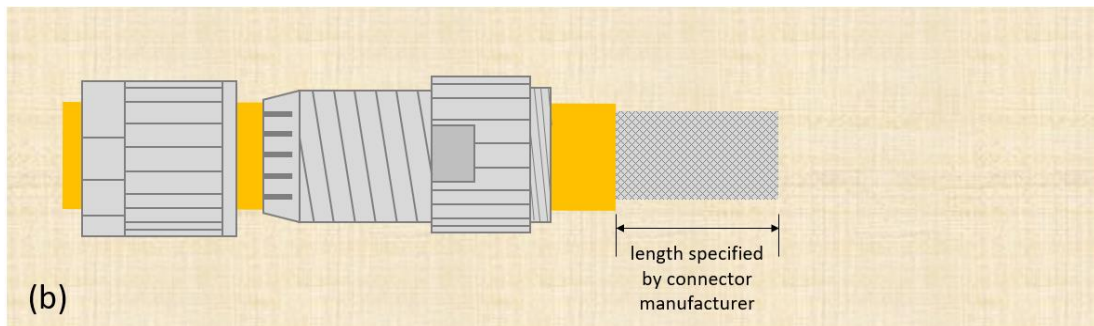

- c) Fold the shield back to the end of the cable jacket, separate the wire pairs and align them as shown. During this process, take particular care to keep the pairs twisted almost down to their end and not to damage the shield itself. Then, trim off the length in excess according to the connector documentation:

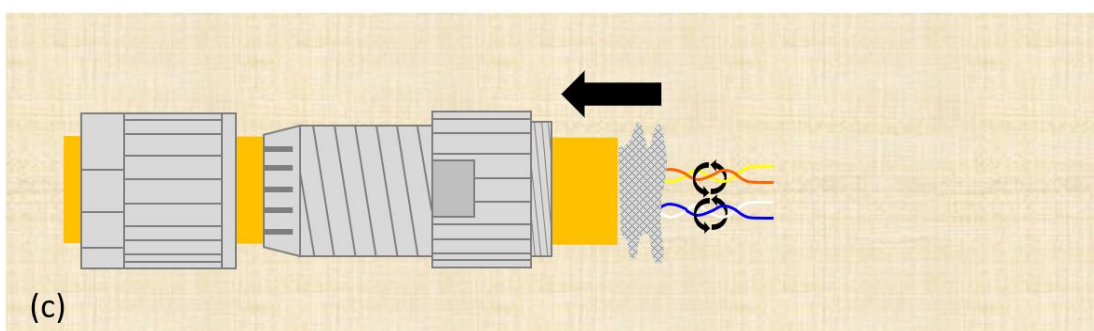

- d) Strip off the conductor insulation for the length specified by the connector manufacturer in the corresponding mounting instructions:

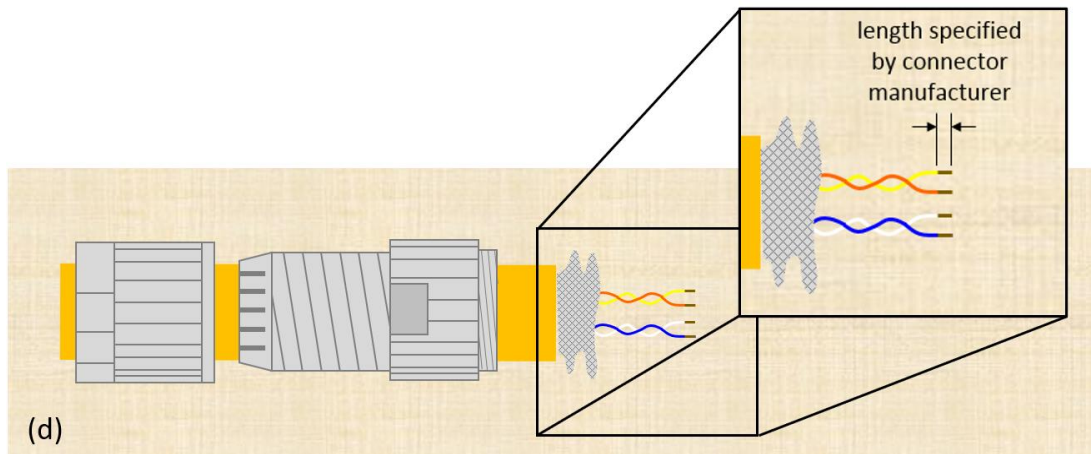

- e) Insert the stripped wires into the holes in the back end of the connector body according to the required pinout assignment, until end stop (wire strands must not stick out). Tighten the stripped wires with the screw if needed.

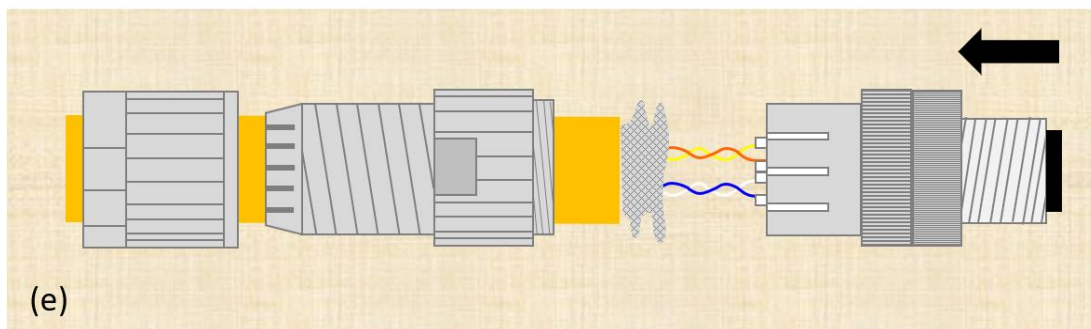

- f) Slide the connector shell over the connector back end. Then, slide the wire gland over the connector shell and tighten. In this process, take particular care not to overtighten the wire gland causing damage to the connector:

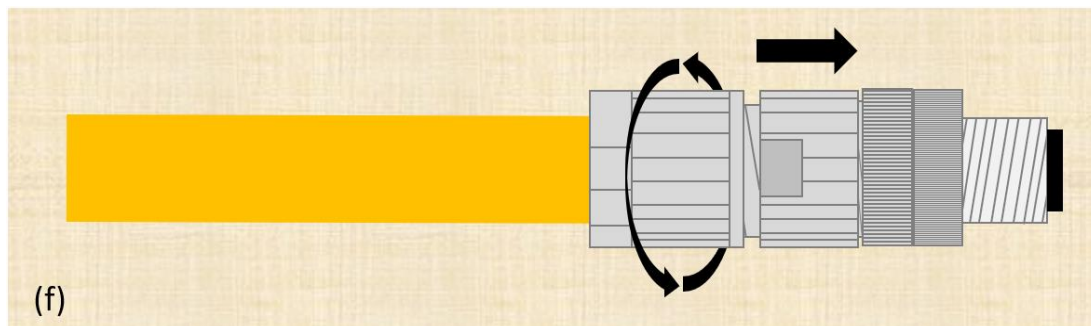

- g) Finally, check the connection of each wire between cable ends with a tester.

In case of four-pair cables, the wire colour standard and connector pin assignment are defined in the TIA-568-C specification. Two different connection schemes are described, referred as T568A and T568B respectively.

The wire colour and pinout assignment defined by the TIA-568-C are different from the one described in the IEC 61918, as shown in Figure 40. The two standards are compared in Table 15.

Table 15: wire color correspondence between ISO 61918 and TIA-568-C

Signal	RJ45	M12	Color IEC 61918	Color TIA-568-C (T568A)	Color TIA-568-C (T568B)
TD+	1	1	YE	WH/GN	WH/OG
TD-	2	3	OG	GN	OG
RD+	3	2	WH	WH/OG	WH/GN
RD-	6	4	BU	OG	GN
	4	-	-	BU	BU
	5	-	-	WH/BU	WH/BU
	7	-	-	WH/BN	WH/BN
	8	-	-	BR	BN

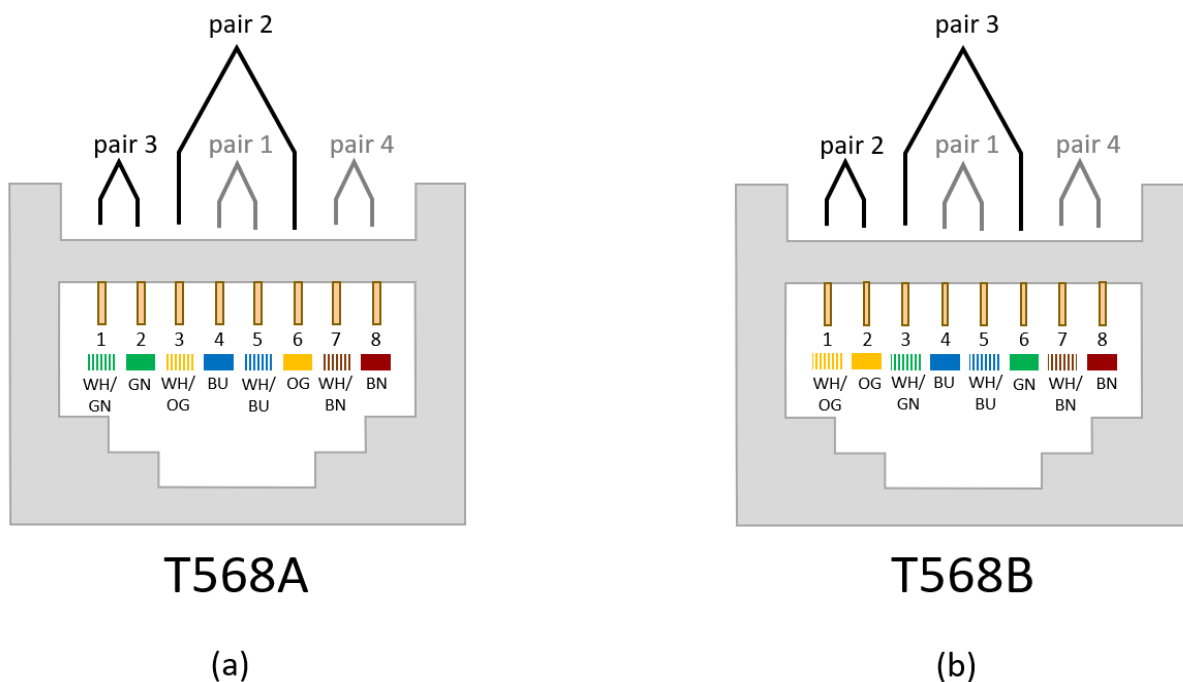

Figure 40: cabling schemes for RJ45 connectors according to TIA-568-C

As described in Subclause 5.4.1, a pin assignment according to the T568B at both cable ends should be preferred. Nevertheless, the use of straight cables based on T568A at both cable ends, as well as of cross cables, is allowed also other pinout assignment schemes are allowed (with the exception of connections between devices based on Fast Hot-Connect technology, for which straight cables are mandatory).

When assembling connectors to four-pair cables, the same steps described in Subclause 6.4.1 should be followed.

During the connector assembly process, independently on the specific cable and connector type, following rules should always be observed:

- The plastic insulation of the single wires shall not be damaged during the process.
- The twisted pairs should be separated only in the nearest proximity of the connectors. Separating the twisted pairs too early (as shown in Figure 41) could lead to current loops and disturbances.

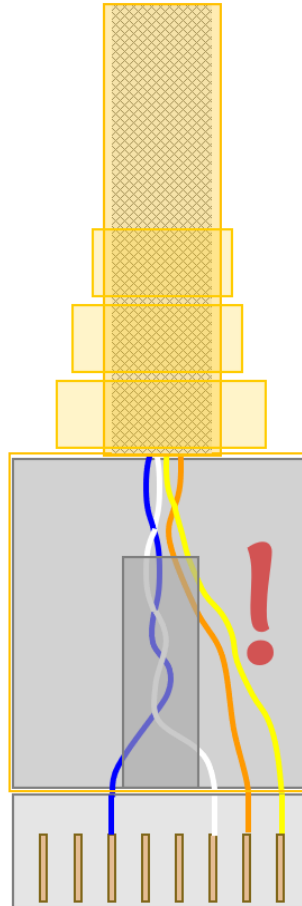

Figure 41: badly assembled RJ45 connector

- The shield should not be damaged or interrupted during the process, as shown in Figure 42. The shield should surround the twisted pairs down to the connector, its continuity should not be interrupted at any point, and it should be soldered to the connector metal cage (the impedance between shield and connector metal cage should be as low as possible).

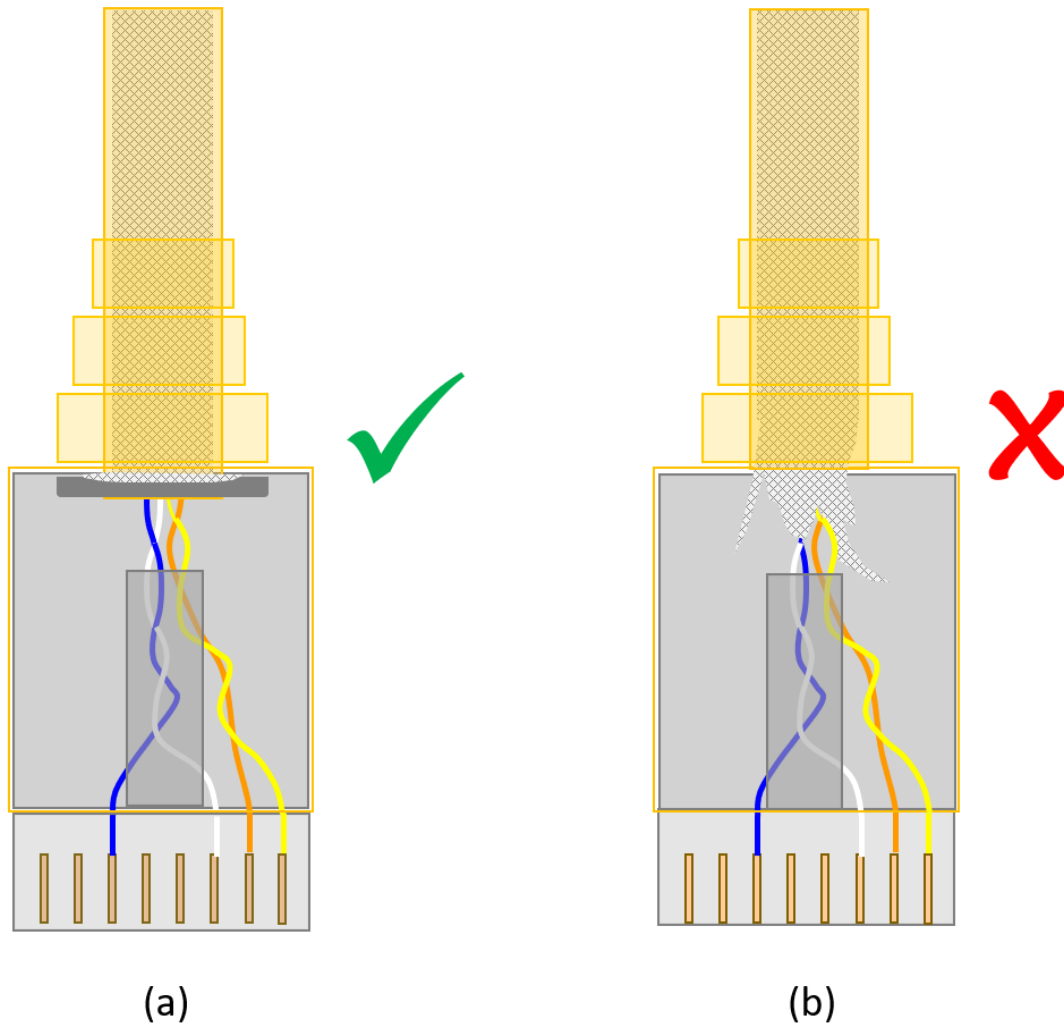

Figure 42: proper and improper connection of cable shield with connector housing

7 Commissioning

7.1 Visual Check

The first step during the commissioning phase of an EtherCAT network should consist in a visual inspection, which should check step-by-step the correct execution of the implementation aspects described in the previous Subclauses. The scope of the visual inspection should be to detect or even prevent all those potential critical points which can be immediately be located, without the need of further tests and specific measuring devices.

A visual inspection of the network installation should enable to detect commissioning errors or potential problems concerning:

- Network structure
- Cable routing
- Cable integrity

Table 16 can be used as a possible checklist during the visual inspection:

Table 16: checklist for network visual inspection

Step	Action	Checked
1	Network structure	
1.1	Is the maximum distance between devices compliant with the network planning (according to Subclause 4.2)?	<input type="checkbox"/>
1.2	Is the maximum number of connections within each end-to-end link compliant with the network planning (according to Subclause 5.3)?	<input type="checkbox"/>
1.3	Are network devices properly connected to earth (according to Subclause 5.7)?	<input type="checkbox"/>
2	Cable routing	
2.1	Are the installed cable type and section compliant with the network planning (according to Subclause 5.4)?	<input type="checkbox"/>
2.2	Is the minimum distance between communication cables and power cables ensured, according to the separation type adopted (according to Subclause 5.6)?	<input type="checkbox"/>
2.3	Do crossings between communication cables and power cables take place with a 90° angle (according to Subclause 6.1)?	<input type="checkbox"/>
2.4	Are coils in communication cables avoided (according to Subclause 6.1)?	<input type="checkbox"/>
2.5	Is the minimum bending radius of communication cables guaranteed (according to Subclause 6.3)?	<input type="checkbox"/>
2.6	Are communication cables specifically protected against sharp edges, especially when tensile forces could cause a permanent cable damage against the sharp edge (according to Subclause 6.3)?	<input type="checkbox"/>

Step	Action	Checked
2.7	Are strain relief components installed wherever tensile forces could permanently damage cables and connectors (according to Subclause 6.3)?	<input type="checkbox"/>
2.8	Are torsional forces avoided, wherever no specifically designed cables are used (according to Subclause 6.3)?	<input type="checkbox"/>
2.9	Are communication cables protected against crushing by moving parts (according to Subclause 6.3)?	<input type="checkbox"/>
3	Cable integrity	
3.1	Is the cable coating damaged anywhere between the two endpoints?	<input type="checkbox"/>
3.2	Are communication cables clearly crushed by strain relief or external earthing clips (according to Subclauses 6.1 and 6.3)?	<input type="checkbox"/>
3.3	Is the cable shield damaged or torn in proximity of cable connectors, or in correspondence to external shield earthing clips (according to Subclause 6.1)?	<input type="checkbox"/>
3.4	When all devices are powered on, Link/Activity LED of all connected interfaces fixed on or flickering (according to Subclause 4.4)?	<input type="checkbox"/>
3.5	Is the time needed to establish the link clearly longer than that for similar configurations, and clearly longer than that observed when using short cables? Is this time clearly longer than 6÷7 seconds after the device power-on?	<input type="checkbox"/>

7.2 Measurement of Channel Physical Parameters

The verification of the channel physical parameters within an EtherCAT network can be performed at different levels, using measuring instruments of growing complexity and costs.

It is highly recommended always to add measurement results obtained during the commissioning phase to the machine or plant documentation, in order to be able to trace later changes in the parameter values and therefore to detect problems potentially emerging during the machine or plant life cycle.

7.2.1 Cable Testing

A very simple cable testing can be performed by means of standard, low-cost multimeters (Figure 43). Such devices can be used to check the most relevant physical parameters of cables.

In order to properly interpret the results of cable measurements, the DC resistance of wires and shield should be known from the data provided by the cable manufacturer. If the cable parameter values are

not provided or a certain mismatch is observed between expected and real length values, an initial measurement of a sample cable should be performed.

Aspects which can be checked through a simple cable test are the following:

- Correct pinout assignment on both cable ends, according to the ISO/IEC 61918 (for quad cables) or TIA-568-C (for four-pair cables) pinout standards described in Subclause 6.4.
- Wire continuity between corresponding pins at the two cable ends.
- Cable resistance (given the cable length), short-circuiting pair pins at one cable end, measuring the resistance between the same pins at the other end and comparing the measured resistance value with the one calculated on the basis of the resistance value per unit length declared by the cable manufacturer.
- Cable length (given the cable resistance), dividing the measured cable resistance by the resistance value per unit length declared by the cable manufacturer.

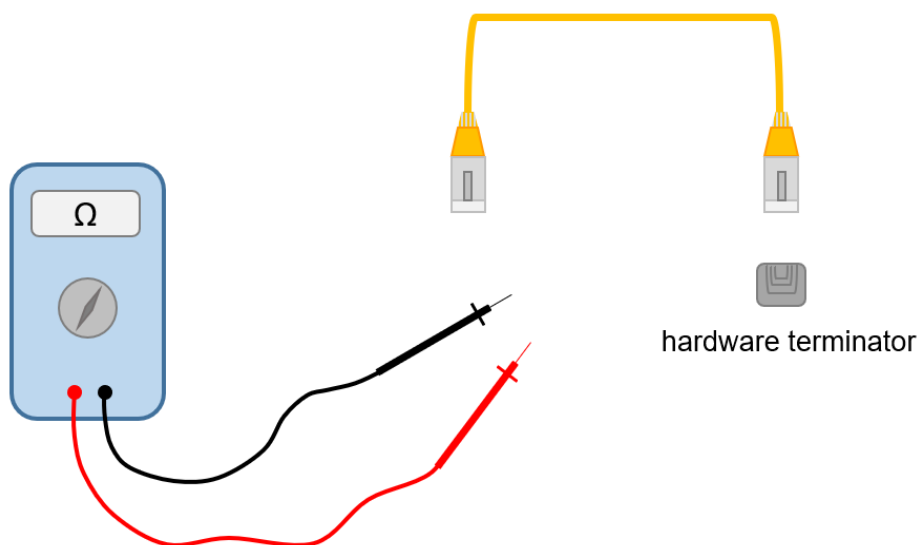

Figure 43: simple cable verification with a multimeter device

The cable testing allows to identify even minor wiring problems if the electrical parameters of the cable and the length are known, and therefore it is typically sufficient during the commissioning phase of an EtherCAT network unless communication errors are detected as described in Subclause 7.4.

7.2.2 Function Testing

The test described in Subclause 7.2.1 allows checking the main cable physical parameters only, but does not represent a real communication test. In order to check the cable behavior under real, 100 Mbit/s full-duplex Ethernet communication, a function testing by means of suitable devices can be performed (as shown in Figure 44: cable qualification with a function tester device). In a function test, predefined Ethernet frames are sent by the measuring unit, and answered by the remote unit. Function testing allows to verify:

- Data corruption during transmission, caused by EM disturbances, bad cable assembly or poor component manufacturing.
- Possible bandwidth limitations for a 100 Mbit/s full-duplex transmission, caused both by cables and intermediate components.
- Possible excessive channel attenuation, caused by intermediate components (the cable contribution to attenuation should have been already evaluated by means of cable testing described in Subclause 7.2.1).

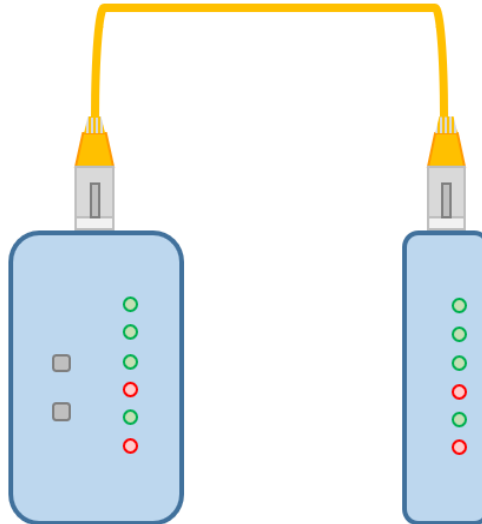

Figure 44: cable qualification with a function tester device

Function testing is recommended for all channels including infrastructural components (like slip rings or media converters) different from mere passive connectors, especially if these infrastructural components have not been previously tested for EtherCAT applications by the component manufacturer. The test should always be performed under the worst-case operating conditions of the infrastructural components (for example, at the maximum rotating speed of the slip ring expected by the specific application).

7.2.3 Acceptance Testing

The channel parameters described in Subclause 5.3, like IL or NEXT, can be measured as a function of frequency by means of suitable, high-end test devices (as shown in Figure 45). Through these testing devices, it is possible to determine detailed information like:

- Channel IL, as a sum of the attenuations introduced by the different parts (cables, intermediate connectors, infrastructural components).
- Channel NEXT, that is the degree of influence between neighbor pairs.

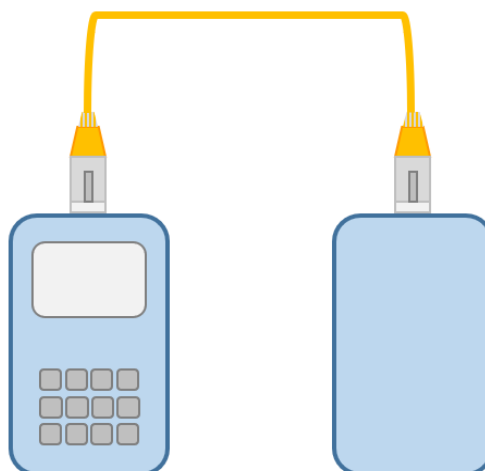

Figure 45: cable certification with an acceptance tester

In case of very high NEXT values, an accurate measurement would be not possible: for this reason, NEXT values greater than 40 dB should be considered always as an index of good performance. In case of short cables, the same could be assumed for ACR values greater than 30 dB.

Acceptance tests typically require very expensive test devices. The application of the rules of structured cabling described in Subclause 5.3, together with a precise knowledge of the physical parameters of all channel parts (cables, intermediate connectors, infrastructural components), typically prevent from the need to directly measure the channel physical parameters. Therefore, performing an acceptance testing for all channels within an EtherCAT network is not generally required during the commissioning phase.

An acceptance testing during of the commissioning phase of the EtherCAT network should be performed only when the physical parameters of the parts forming a channel are unknown, and communication errors are detected as described in Subclause 7.4.

Indication for device manufacturers

A test measuring the physical parameters as a function of frequency by means of suitable devices is instead highly recommended for all manufacturers of infrastructural components (like slip rings, or media converters) which are not EtherCAT devices.

The test should measure the physical parameters between the component input and output points, and should include all the intermediate parts (cables, metallic contacts, intermediate connectors), as shown in Figure 46.

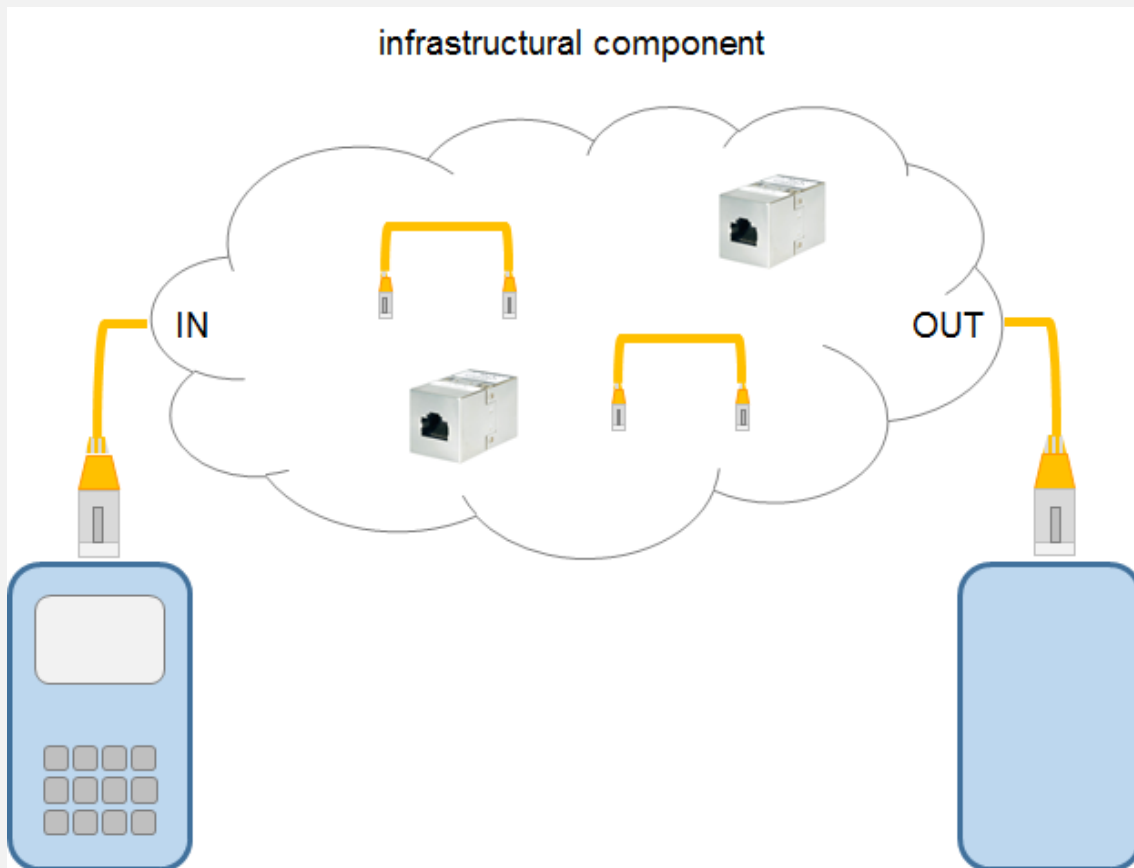

Figure 46: parameter measurement for infrastructural components

The test should always be performed under the worst-case operating conditions declared in the component datasheet or documentation.

The test results should also be reported in the component datasheet or documentation, in order to provide users with the information required to properly plan a channel without the need to perform a function testing during the network commissioning phase themselves.

7.2.4 Checklist for Channel Measurements

When measuring the communication cables, the checklist reported in Table 17 can be used:

Table 17: checklist for channel measurements

Step	Action	Checked
1	Cable testing	
1.1	Is the cable pinout assignment correct (according to Subclause 6.4)?	<input type="checkbox"/>
1.2	Are short-circuits between different pair conductors, or between conductors and shield, avoided?	<input type="checkbox"/>
1.3	Is the cable resistance compliant with the tolerable values (according to Subclause 5.4)?	<input type="checkbox"/>
2	Function testing	
2.1	Are test frames sent and received without errors?	<input type="checkbox"/>
3	Acceptance tests	
3.1	Is the cable attenuation (IL) of each channel compliant with the specified values (according to cable specification/ test measurement)?	<input type="checkbox"/>
3.2	Is the cable near-end crosstalk (NEXT) of each channel compliant with the specified values (according to cable specification/ test measurement)? The measurement of values in the range of 50dB and higher requires no exact match but a high value.	<input type="checkbox"/>

7.3 Measurement of Earthing System

During the commissioning phase of an EtherCAT network, the implementation of the earthing system should always be checked by means of a standard multimeter.

The scope of this measurement should be to verify that each component of the EtherCAT network which could influence the communication performances is properly connected to the system earth. A proper earthing of all components directly or indirectly involved in the network infrastructure will prevent current loops from affecting the communication.

When checking the earthing system, the check list reported in Table 18 could be used.

Table 18: checklist for earthing system

Step	Action	Checked
1	Measure the impedance between each cabinet and the local earth. Is this impedance $< 0,1 \Omega$?	<input type="checkbox"/>
2	Measure the impedance between different local earths at different points in the network. Is this impedance $< 0,1 \Omega$?	<input type="checkbox"/>
3	Measure the impedance between the PE pin of each device (if available) and the local earth (like DIN rail, or metallic mounting support). Is the measured impedance $< 1 \Omega$? If no PE pin is available, is the device connected to the local earth in another way (like metallic clamps on the back of the device, or metallic contact with the mounting screws) with a measured impedance $< 1 \Omega$?	<input type="checkbox"/>
4	Measure the impedance between the metallic part of each EtherCAT connector (with EtherCAT cables disconnected) and the local earth (i.e. DIN rail, or metallic mounting support). If the measured impedance is very high but is not an open circuit (i.e. in the order of magnitude of $M\Omega$), no further check should be performed. If the measured impedance is low, than it should be $< 1 \Omega$. If this is not the case, it should be checked that the cable shield has been connected to the cabinet or device chassis with suitable cable clips having a very low impedance ($< 0,1 \Omega$). If the measured impedance is an open circuit, it should be checked that the cable shield have been connected to the cabinet or device chassis with suitable cable clips having a very low impedance ($< 0,1 \Omega$).	<input type="checkbox"/>

7.4 EtherCAT-Specific Diagnostics

All EtherCAT slave devices provide diagnostic information at hardware level in the form of error counters which are incremented and reported at standard memory addresses by ESCs.

EtherCAT masters or master configuration tools should provide functionalities which allow users to monitor the hardware error counters provided by ESC. This could be done, for example, in the form of monitoring windows within the master configuration tool, or of function blocks which can read the error counter values from the PLC program.

The hardware error counters should always extensively checked during the commissioning phase, in order to detect communication errors, locate problems or critical points, and in case change the network planning or installation. The monitoring of the error counters during the commissioning phase should be performed in all the possible operating conditions of the machine or plant.

The hardware error counters should also be checked during the life cycle of the machine or plant, every time the network communication starts having problems.

7.4.1 Lost Link Counters

The ESC increments each Lost Link Counter when the corresponding port detects an interruption of the channel continuity. Link Lost counters are described in Table 19.

Table 19: Lost Link Counter registers

Physical Address	Meaning	Size
0x0310	Lost Link Counter Port 0	1 byte
0x0311	Lost Link Counter Port 1	1 byte
0x0312	Lost Link Counter Port 2	1 byte
0x0313	Lost Link Counter Port 3	1 byte

As the continuity of the physical medium should never be interrupted, these counter should never be incremented during the machine or plant operation, unless one or more devices are intentionally powered-off or disconnected from the network.

7.4.2 Physical Layer Error Counters

The ESC increments each Physical Layer Error Counter when the corresponding physical layer interface of the corresponding port (the PHY chip, for 100BASE-TX and 100BASE-FX channels) reports a symbol error. This indicates a corruption of the signal.

Symbol error means specifically that a particular bit sequence is not recognized by the physical layer interface as one of the valid ones according to the specific hardware coding method used. As idle symbols are sent on the physical medium even when no frames are transmitted, Physical Layer errors can occur both within and outside EtherCAT frames. Physical Layer Error Counters are described in Table 20.

Table 20: Physical Layer Error Counter registers

Physical Address	Meaning	Size
0x0301	Physical Layer Error Counter Port 0	1 byte
0x0303	Physical Layer Error Counter Port 1	1 byte
0x0305	Physical Layer Error Counter Port 2	1 byte
0x0307	Physical Layer Error Counter Port 3	1 byte

A completely error-free data transmission is physically not possible. In industrial environment, a bit error rate of $1 \cdot 10^{-12}$ is typically taken as index of good performances. An occasional increment of the Physical Layer Error Counters which is compatible with this value of bit error rate is not therefore symptom of a problem. A critical condition is instead detected by much faster or burst increments of the Physical Layer Error Counters.

7.4.3 Frame Error Counters

The ESC increments each Frame Error Counter (also referred to as CRC Error Counter) when the corresponding port detects an error when performing the cyclic redundancy check.

The cyclic redundancy check is always performed by each ESC port when the frame is received from outside. Frame Error Counters are described in Table 21.

Table 21: Frame Error Counter registers

Memory Address	Meaning	Size
0x0300	Frame Error Counter Port 0	1 byte
0x0302	Frame Error Counter Port 1	1 byte
0x0304	Frame Error Counter Port 2	1 byte
0x0306	Frame Error Counter Port 3	1 byte

A completely error-free data transmission is physically not possible. In industrial environment, a bit error rate of $1 \cdot 10^{-12}$ is typically taken as index of good performances. An occasional increment of the Frame Error Counters which is compatible with this value of bit error rate is not therefore symptom of a problem. A critical condition is instead detected by much faster or burst increments of the Frame Error Counters.

As Physical Layer Error Counters can increment both within and outside frames while Frame Error Counters can be incremented only within frame, in case of external random disturbances an increment of both Physical Layer and Frame Error Counters should be observed on the long term. A high increment of an Physical Layer Error Counter with no increment of the corresponding Frame Error Counter would indicate more probably an electrical problem within the device.

8 Summary

The communication infrastructure represents the core of a machine or plant: it determines the amount of data which can be exchanged between controllers and field devices, the minimum cycle times which can be reached, as well as the degree of synchronization of different components.

In case of EtherCAT networks, the implementation of the communication infrastructure consists of three phases:

- **Planning.** The scope of the planning phase is to check and define in advance all those aspects which determine the architecture of a machine or plant. Some of its tasks are the definition of the environmental conditions (with specific care to particularly critical points), the choice of EtherCAT devices, the dimensioning of the hardware connections, the selection of cables and connectors, and of suitable infrastructure components.
- **Assembling.** The assembling phase aims to properly translate the indications produced by the planning phase into a real network infrastructure. Core tasks are to provide proper protection to the communication infrastructure, both from the mechanical and from the electromagnetic point of view, as well as to correctly assemble the components of the communication infrastructure like connectors.
- **Commissioning.** The proper implementation of the communication infrastructure should always be tested in order to immediately detect planning errors as well as assembly weaknesses. The network infrastructure can be checked at first via simple measurements performed by means of off-the-shelf measuring devices. In case of particularly critical points within the network, deeper measurements can be performed using more complex instruments. The extensive diagnostic information provided by EtherCAT devices allows to locate errors and critical points within the network infrastructure.

All the results of the planning, assembling and commissioning phases should be included into the documentation of a machine or plant, in order to allow a fast detection of changes in the infrastructure parameters and behavior, and therefore an easier maintenance process during the life cycle of the machine or plant itself.